

NOMAD RAY

QUICK START GUIDE

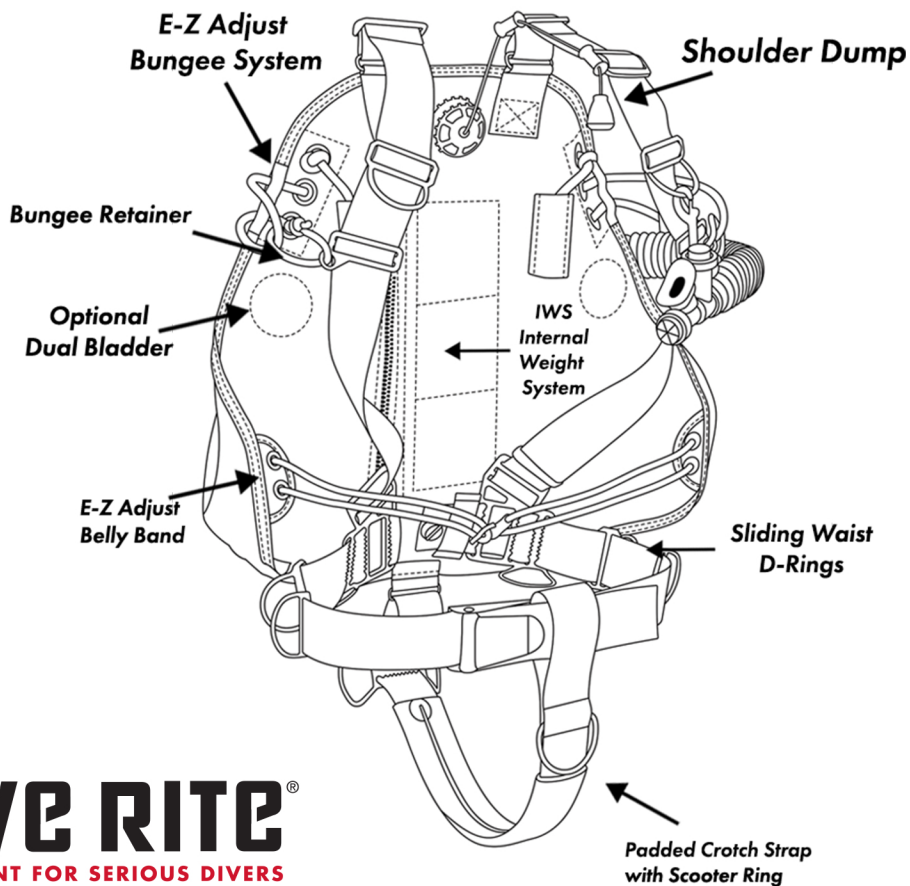
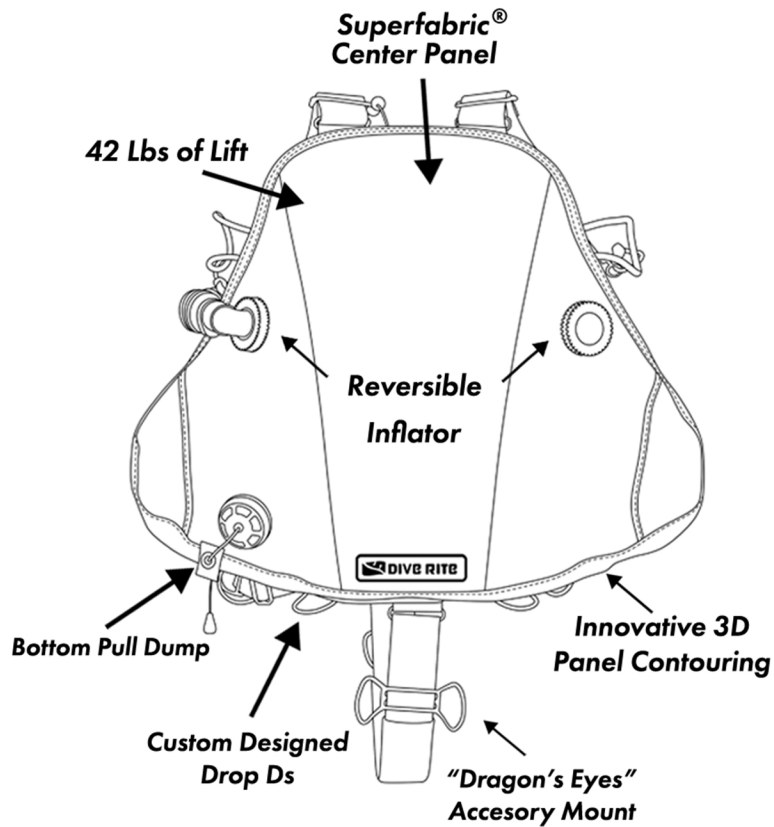

This quick start guide is **NOT** a replacement for proper training!!!

Sizing Your Nomad RAY

1. Line the bottom edge of the wing up with the top of your butt.
2. Pull the waist strap snug on your hips and tighten the buckle.
(NOTE: The waist strap will ride lower than on a traditional harness)
3. Adjust the crotch strap until it pulls on the the waist strap slightly.
4. Pull the slack out from the shoulder straps at the bottom plate.
5. Adjust hardware to fit your preferences.
6. Adjust tank bungees and belly bands by pulling to length and tying an overhand knot.
7. Once you are satisfied with the fit, trim the excess webbing and bungee.

Using the IWS (Internal Weight System)

1. Unzip the access zipper.
2. Select the desired position for weight.
3. Open the hook and loop pocket and insert the weight.

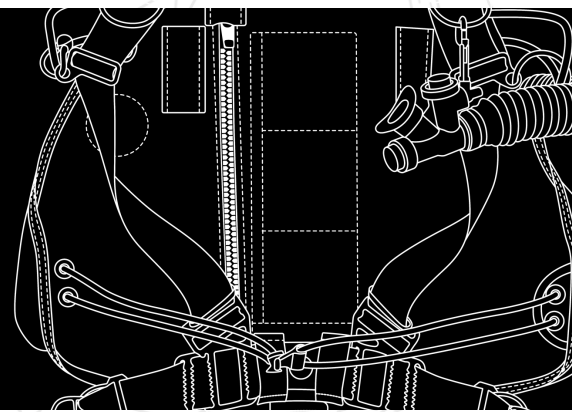

Maintenance and Care

- Rinse thoroughly with fresh water after each use
- Drain any water out of the aircell and ensure the unit dries completely before storage
- Store your Nomad RAY in a cool, dark place

WWW.DIVERITE.COM

