



PETREL • 3

Operations Manual



Rebreather Controller Model



Powerful • Simple • Reliable

Table of Contents

DiveCAN Petrel 3

Table of Contents.....	2
1. Introduction.....	6
1.1. Models Covered by this Manual.....	7
1.2. What is DiveCAN®?.....	8
1.3. DiveCAN® Advantages.....	9
2. Basic Operation	10
2.1. Turning On.....	10
2.2. Buttons	11
3. The Main Screen.....	12
3.1. The Top Row	13
3.2. The Center Row	15
3.3. The Bottom Row	16
4. Info Screens	18
5. Notifications.....	27
5.1. Types of Notifications.....	27
5.2. Vibration Alerts	29
5.3. List of primary notifications.....	30
6. Compass.....	33
7. Air Integration	35
7.1. What is AI?	35
7.2. Basic AI Setup	36
7.3. AI Displays.....	39
7.4. Using Multiple Transmitters.....	40
7.5. Transmitter Connection Issues	41
8. Example Dives	42
8.1. Basic Setup.....	42
8.2. Simple Example Dive	43
8.3. Complex Example Dive	45
9. Decompression and Gradient Factors.....	49
9.1. Decompression information accuracy	50
10. Menus.....	51
10.1. Menu Structure	52
10.2. Menu Reference.....	53

10.2.1.	Turn Off.....	53
10.2.2.	Calibration	53
10.2.3.	Calibration Problems.....	54
10.2.4.	Switch Setpoint	55
10.2.5.	Select Gas.....	55
10.2.6.	Radio Station Gases.....	56
10.2.7.	Select Gas Menu Styles	57
10.2.8.	Switch to CC/BO.....	58
10.2.9.	External PPO2 Monitoring	58
10.2.10.	Setpoint -> .19	59
10.3.	Dive Setup	60
10.3.1.	Edit Low Setpoint.....	60
10.3.2.	Edit High Setpoint.....	60
10.3.3.	Define Gas	61
10.3.4.	New Style Define Gas.....	62
10.3.5.	Deco Planner	63
10.3.6.	Conservatism.....	66
10.3.7.	NDL Replacement Display	66
10.3.8.	Brightness.....	67
10.3.9.	Vibration On/Off	67
10.3.10.	Test Vibration	67
10.4.	Dive Log	68
10.4.1.	Display Log	68
10.4.2.	Edit Log	68
10.4.3.	Next Log.....	69
10.4.4.	Restore Mode	69
10.4.5.	Delete All Logs	69
10.4.6.	Start Bluetooth	69
11.	System Setup Reference	70
11.1.	Mode Setup	70
11.2.	Deco Setup	71
11.3.	AI Setup	72
11.3.1.	TX Setup.....	72
11.3.2.	Tank Setup.....	73
11.4.	BO Gases.....	75
11.5.	CC Gases	75
11.6.	O2 Setup	75
11.7.	Auto Setpoint Switch.....	76
11.8.	Alerts Setup	77
11.9.	Display Setup.....	77
11.10.	Compass.....	78
11.11.	System Setup	80
11.12.	Advanced Config	81
11.12.1.	Advanced Config 1.....	82
11.12.2.	Advanced Config 2.....	83

11.12.3. Advanced Config 3	84
11.12.4. Advanced Config 4	84
12. Firmware Update and Log Download.....	85
12.1. Shearwater Cloud Desktop.....	86
12.2. Shearwater Cloud Mobile.....	89
13. Changing the Battery.....	91
13.1. Battery Type Selection	92
13.2. Behavior on Battery Change.....	93
13.2.1. Decompression Tissue Loading	94
14. Storage and Maintenance.....	95
15. Servicing	95
16. Glossary.....	96
17. Specifications.....	97
18. List Of Petrel 3 Models.....	98
19. Regulatory Information	99
20.Contact.....	101



DANGER

This computer is capable of calculating deco stop requirements. These calculations are at best a guess of the real physiological decompression requirements. Dives requiring staged decompression are substantially more risky than dives that stay well within no-stop limits.

Diving with rebreathers and/or diving mixed gases and/or performing staged decompression dives and/or diving in overhead environments greatly increases the risk associated with scuba diving.

YOU REALLY ARE RISKING YOUR LIFE WITH THIS ACTIVITY.



WARNING

This computer has bugs. Although we haven't found them all yet, they are there. It is certain that there are things that this computer does that either we didn't think about, or planned for it to do something different. Never risk your life on only one source of information. Use a second computer or tables. If you choose to make riskier dives, obtain the proper training and work up to them slowly to gain experience.

This computer will fail. It is not whether it will fail but when it will fail. Do not depend on it. Always have a plan on how to handle failures. Automatic systems are no substitute for knowledge and training.

No technology will keep you alive. Knowledge, skill, and practiced procedures are your best defense (except for not doing the dive, of course).

1. Introduction

The Shearwater Petrel is an advanced technical diving computer for open and closed circuit divers.

Although we strive to make the Petrel easy enough to use without reading the manual, please take some time to read this manual to get the best performance from your new computer. Diving involves risk and education is your best tool for managing this risk.

Features

- High-contrast 2.6" AMOLED display
- Rugged computer construction with titanium bezel
- DiveCAN communications for robust connections to rebreathers
- A menu system that adapts to diving status
- Powerful vibration alerts
- Programmable depth sampling rates
- Depth sensor calibrated to 130 msw
- Depth sensor function past 300 msw
- Crush pressure rating of 290 msw
- 5 CC & 5 BO gases
- Any combination of Oxygen, Nitrogen and Helium (Air, Nitrox, Trimix)
- Gases can be added and changed during a dive
- Automatic PPO2 set-point switching (configurable)
- Two PPO2 set-points, each of which can be set between .5 and 1.5
- Bühlmann ZHL-16C with gradient factors standard
- Optional VPM-B decompression model
- No lockout for violating deco stops
- CNS Tracking
- Gas Density Tracking
- Full decompression planner built in
- Simultaneous wireless pressure monitoring of up to 4 cylinders
- Tilt compensated digital compass with multiple display options
- Bluetooth Dive log uploading to Shearwater Cloud
- Bluetooth Firmware Updates

1.1. Models Covered by this Manual

This manual provides operating instructions for the Petrel 3 **DiveCAN® Rebreather Controller** model. For instructions on the Standalone (SA) and Analog PPO2 monitoring Petrel models, see the documents [Shearwater Petrel 3 Technical Modes Operating Instructions](#) and [Shearwater Petrel 3 Recreational Modes Operating Instructions](#).

A complete list of models this manual applies to can be found on [page 98](#).



Firmware Version: V91

This manual corresponds to firmware version V89.

Feature changes may have been made since this release and might not be documented here.

[Check the release notes on Shearwater.com for a complete list of changes since the last release.](#)

1.2. What is DiveCAN®?

DiveCAN® is a digital communications standard developed specifically for rebreathers.

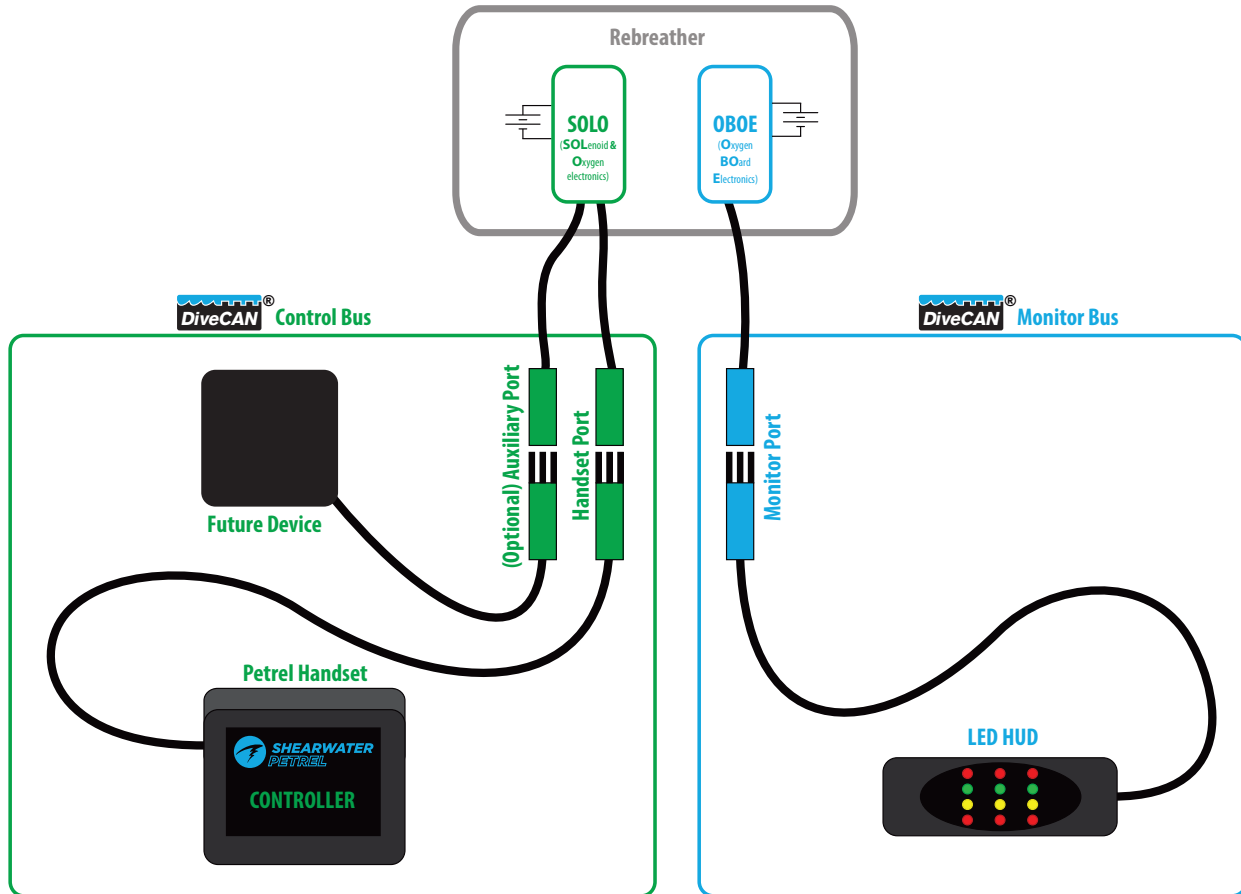

DiveCAN® connections allow rebreather components to communicate

A minimum configuration has a **Control Bus** with a handset connected to rebreather electronics ("bus" is a term used to describe the connections between communicating electronic modules).

Depending on your rebreather, a secondary **Monitor Bus** may be used. This independent bus provides backup PPO2 monitoring in the event of a failure of the primary control bus.

Spare auxiliary ports may be included for additional devices or future expansion. Even if your rebreather does not have a spare port, additional devices can be added with the use of Y-cables.

DiveCAN® devices connect together using specially designed underwater connectors. This allows easy disconnection of devices for upgrades, repair, and travel.

1.3. DiveCAN® Advantages

The DiveCAN® standard was designed to improve rebreather electronics. It offers the following advantages over the previous generation of analog wiring:

- Robust error-checked communications. A message is either received correctly or it isn't. Compare this with analog wiring where corrosion or poor connections can result in incorrect data being used.
- Upgradable and expandable. As new technologies are introduced, they can be plugged into existing rebreathers.
- Components (handset, HUD, etc) can be easily removed for travel, repair, backup, and upgrades.
- Modular design compartmentalizes critical functions for redundancy. For example, the Solenoid and Oxygen electronics (SOLO) can measure and inject oxygen independently of the handset. If the handset is unplugged or damaged, the SOLO can continue to control loop PPO2.

The DiveCAN® connectors are shown below. These connectors are miniature versions of the underwater connectors used in the oil and gas industry. They are robust and rated to 2000ft underwater.

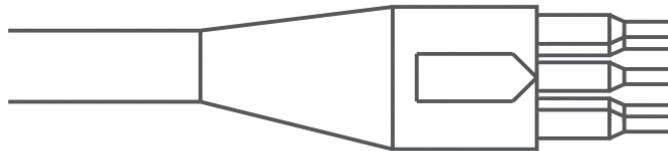

Male Connector

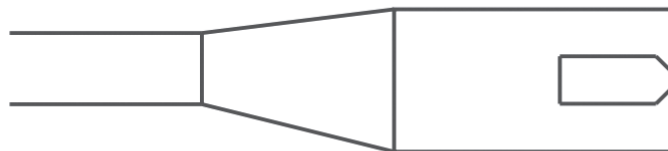

Female Connector

2. Basic Operation

2.1. Turning On

To turn the Petrel on, press both the MENU (left) and the SELECT (right) buttons at the same time.

Auto-On

The Petrel will automatically turn-on when submerged underwater. For rebreather controller models, this is based on the presence of water.

The Petrel 3's buttons act as wet contacts. All other versions of the Petrel are only activated by pressure, not the presence of water.

2.2. Buttons

Two titanium piezo-electric buttons are used to change settings and view menus.

All Petrel 3 operations are simple single button presses.



Don't worry about remembering all the button rules below. Button hints make using the Petrel 3 easy.

MENU (Left) button

From main screen	Brings up menu
In a menu	Moves to the next menu item
Editing a setting	Changes the setting's value

SELECT (Left) button

From main screen	Steps through info screens
In a menu	Performs command or starts editing
Editing a setting	Saves the setting's value

BOTH BUTTONS

When Petrel 3 is off pressing MENU and SELECT at the same time will turn the Petrel 3 on. No other operation requires pressing both buttons at the same time.



BUTTON HINTS

When in a menu, button hints label each button.

For example, the hints to the right tell us:
 use MENU to **change** the brightness value.
 use SELECT to **save** the current value.

DEPTH	TIME	SURFACE
0		2hr15mn
.70	.70	.70
Brightness		Auto
Change		Save
MENU hint		SELECT hint

3. The Main Screen

The main screen shows the most important information needed for technical diving.

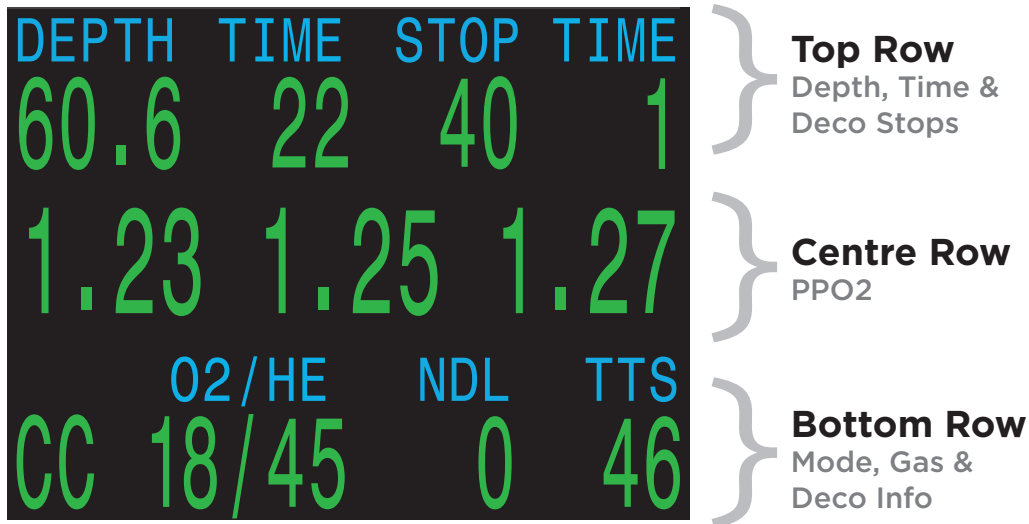

Colour Coding

Colour coding of text draws attention to problems or unsafe situations.

WHITE text indicates normal conditions.

YELLOW is used for warnings that are not immediately dangerous but should be addressed.

FLASHING RED is used for critical alerts that could be life threatening if not immediately addressed.



Sample warning - a better gas is available

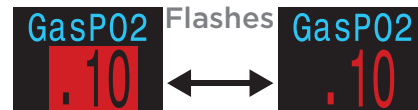

Sample critical alert - continuing to breathe this gas could be fatal

i COLOR BLIND USERS

The warning or critical alert states can be determined without the use of color.

Warnings display on a solid inverted background. Warning - doesn't flash.



Critical alerts flash between inverted and normal text. Critical alert - flashes.



3.1. The Top Row

The top row shows depth and time information



Depth

Imperial: In feet (no decimal places).

Metric: In meters (displays with 1 decimal place up to 99.9m)

Note: If the depth shows a **Flashing Red** zero, then the depth sensor needs service.



in feet

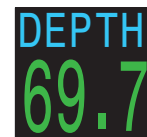

in meters

Ascent Bar Graph

Shows how fast you are currently ascending.

Imperial: 1 arrow per 10 feet per minute (fpm) of ascent rate.

Metric: 1 arrow per 3 meters per minute (mpm) of ascent rate.

Green when 1 to 3 arrows, **Yellow** when 4 to 5 arrows, and **Flashes Red** when 6 arrows or more.



Note: Deco calculations assume 33fpm (10mpm) ascent rate.

Dive Time

The length of the current dive in minutes.

The seconds display as a bar drawn below the word “Time.”
It takes 15 seconds to underline each character in the word.
Does not display the seconds bar when not diving.



Battery Icon

Yellow when the battery needs to be changed.

Red when the battery must be replaced immediately.

The default behavior is that battery icon is shown on the surface but disappears when diving. If low or critical then the battery icon will appear while diving.



BLUE
Battery OK



YELLOW
Battery low.



RED
Replace immediately!

Stop Depth and Time

Stop – The next stop depth in the current units (feet or meters).

This is the shallowest depth to which you can ascend.



Stop 27 meters for 2 min

Time – The time in minutes to hold the stop.

Will **Flash Red** if you ascend shallower than the current stop.

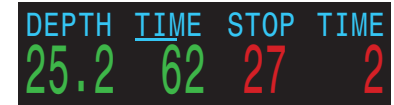

Decompression Stop Violated

By default the Petrel uses a 10ft (3m) last stop depth. At this setting, you may perform the last stop deeper if you choose. The only difference is that the predicted time-to-surface will be shorter than the actual TTS since off-gassing is occurring slower than expected.

There is also an option to set the last stop to 20ft (6m) if you wish.

Surface Interval

When on the surface, the STOP DEPTH and TIME are replaced by a surface interval display.



2 hour and 15 minute surface interval

Shows the hours and minutes since the end of your last dive. Above 4 days, the surface interval is displayed in days.

The surface interval is reset when the decompression tissues are cleared.

Deco Clear Counter

When deco clears the STOP DEPTH and TIME are replaced by a counter that begins counting up from 0.



Deco Clear Counter

3.2. The Center Row

The center row of a DiveCAN controller always displays the PPO2 as measured by the three external O2 sensors.



All centre row positions show PPO2 information

PPO2 units are absolute atmospheres (1ata = 1013mbar).

PPO2 **Flashes Red** when less than 0.40 or greater than 1.6. These limits can be adjusted in the Adv. Config 2 menu.



PPO2 Unsafe

When a sensor is voted out, it displays in **Yellow**. Voting is performed to determine which sensors are most likely to be correct if the readings disagree. A sensor that is within 20% of either of the other sensors passes the voting and is included in the system average PPO2 (used to control O2 injection and calculate decompression).



Sensor 3 voted out

When the O2 sensors require calibration, the PPO2 value will display as FAIL. Instructions can be found in the Calibration section.



Requires Calibration



Voting Failed

If no consensus can be found between the three O2 sensors, then voting has failed. This displays as PPO2 values alternating with "VOTING FAILED".



When voting fails, the solenoid will not inject O2 to maintain the PPO2 setpoint.

If this occurs, follow the training guidelines from your rebreather manufacturer or training agency.

When voting fails the decompression calculations use the PPO2 from the lowest sensor (most conservative value), down to a minimum PPO2 of 0.16.

3.3. The Bottom Row

The bottom row displays the current mode, gas and decompression information.



Circuit Mode

The current breathing configuration. One of:

CC = Closed circuit.

BO = Open circuit bailout (bailout so displays in Yellow).

CC

BO

Current Gas (O2/He)

The current gas shown as a percentage of Oxygen and Helium. The remainder of the gas is assumed to be Nitrogen.

In closed circuit mode, this gas is the diluent. In open circuit mode this is the breathing gas.

Displays in Yellow when there is better deco gas available than the current gas.

O2/HE
21/00

*Air:
21% O2
79% N2*

O2/HE
10/50

*Trimix:
10% O2
50% He
79% N2*

O2/HE
21/00

*A better
deco gas is
available*

No Decompression Limit (NDL)

The time remaining, in minutes, at the current depth until decompression stops will be necessary. Displays in Yellow when the NDL is less than the low NDL Limit (Default 5 minutes.)

Once NDL reaches 0 (i.e. deco stops needed), the NDL display is just wasting space. To address this, a few different values can be set to replace the NDL (see Dive Setup → NDL Display).

The options are:

- Ceiling
- @+5
- Delta+5
- GF99
- SurGF

NDL
20

NDL
5

Each of these values is discussed further in the next section.

Time-to-Surface (TTS)

The time-to-surface in minutes. This is the current time to ascend to the surface including the ascent plus all required deco stops.



All decompression information including Deco Stops, NDL, and Time to surface are predictions that assume:

- Ascent rate of 10mpm / 33fpm
- Decompression stops will be followed
- All programmed gases will be used as appropriate

The bottom row is also used to show additional information.

By using only the bottom row for this additional information, the critical information contained on the Top and Center Rows is always available during a dive.

The additional information that can be displayed on the bottom row includes:

- Info** Shows additional dive information.
- Screens:** Press SELECT (right button) to step through info screens.
- Menus:** Allows changing settings.
Press MENU (left button) to enter menus.
- Warnings:** Provide important alerts.
Press SELECT (right button) to clear a warning.

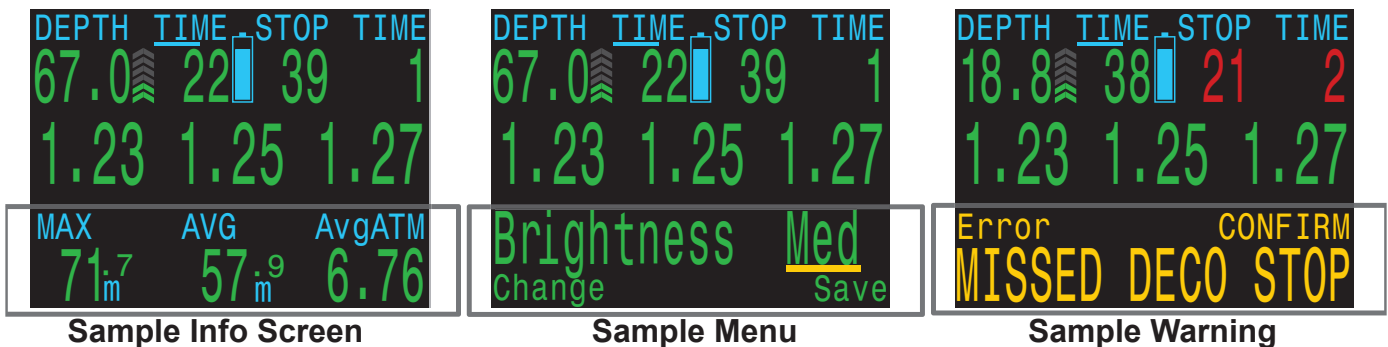

The bottom row is used to display additional information

4. Info Screens

Info screens provide additional information that does not fit on the main screen.

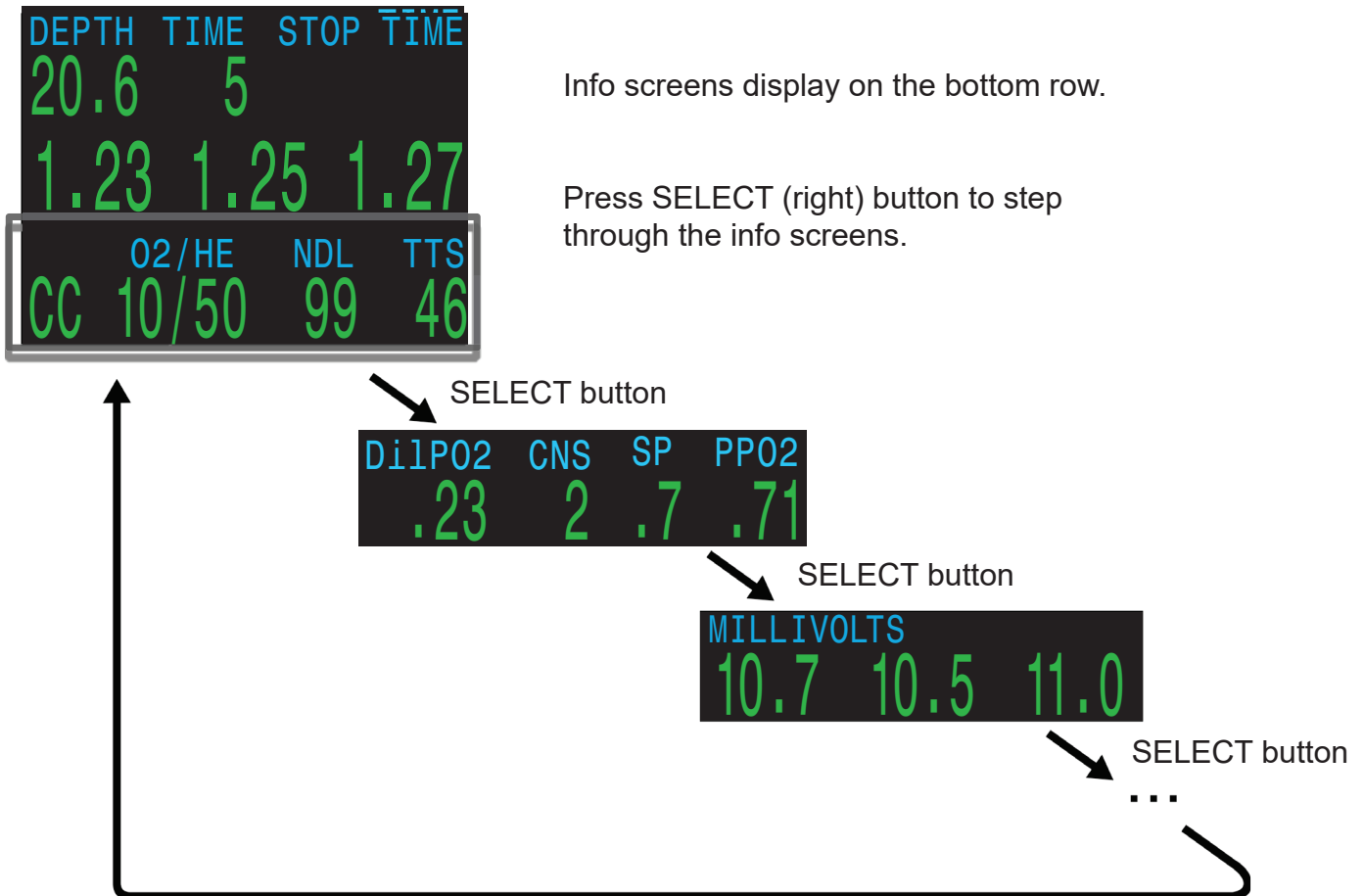

Info screens display on the bottom row.

Press SELECT (right) button to step through the info screens.

From the main screen, the SELECT (right) button steps through info screens.

When all info screens have been viewed, pressing SELECT again will return to the main screen.

Info screens also automatically time-out after 10 seconds, returning to the home screen. This prevents active gas information from being hidden for an extended period.

Note that the Compass, Tissues and AI Info screens do not automatically time out when active.

Pressing the MENU (left) button will return to the home screen at any time.

The next section gives descriptions of the data elements shown on the info screens.

Last Dive Info Screen (surface only)

The maximum depth and dive time from the last dive.



Air integration

Only available if AI feature is turned on. The contents of the AI info line will automatically adapt to the current setup.



More information on AI features, limitations, and displays can be found in the Air Integration (AI) section.

Compass



Marked headings appear in green while reciprocal headings are shown in red. Green arrows point in the direction of your mark when off course by 5° or more.

Compass info row will not time out and is only available when compass feature is turned on.

See the Compass section for more information.

Millivolts



Shows the raw millivolt outputs of external PPO2 cells. This is important information used to understand the O2 cell output behavior over time.

Average Depth

Displays the average depth of the current dive, updated once per second. When not diving, shows the average depth of the last dive.

A digital display with a black background. The word "AVG" is in blue at the top. Below it, the number "21.3" is in green, and "m" is in blue at the bottom right.

Average Depth in Atmospheres (AvgATM)

The average depth of the current dive, measured in absolute atmospheres (i.e. a value of 1.0 at sea level). When not diving, shows the average depth of the last dive.

A digital display with a black background. The text "AvgATM" is in blue at the top. Below it, the number "3.13" is in green.

Maximum Depth

The maximum depth of the current dive. When not diving, displays the maximum depth of the last dive.

A digital display with a black background. The word "MAX" is in blue at the top. Below it, the number "57" is in green, and "m" is in blue at the bottom right.

CNS Toxicity Percentage

Central Nervous System oxygen toxicity loading percentage. **Flashes Red** when 100 or greater.

A digital display with a black background. The text "CNS" is in blue at the top. Below it, the number "11" is in green.

The CNS percentage is calculated continuously, even when on the surface and turned off. When deco tissues are reset, the CNS will also be reset.

A digital display with a black background. The text "CNS" is in blue at the top. Below it, the number "100" is in red.

The CNS value (short for Central Nervous System Oxygen Toxicity) is a measure of your exposure to elevated partial pressures of oxygen (PPO₂) as a percentage of a maximum allowable exposure. As PPO₂ goes up, the maximum allowable exposure time goes down. The table we use is from the NOAA Diving Manual (Fourth Edition). The computer linearly interpolates between these points and extrapolates beyond them when necessary. Above a PPO₂ of 1.65 ata, the CNS rate increases at a fixed rate of 1% every 4 seconds.

During a dive the CNS never decreases. When back at the surface, a half-life of elimination of 90 minutes is used. So for example, if at the end of the dive the CNS was 80%, then 90 minutes later it will be 40%. In 90 more minutes it will be 20%, etc. Typically after about 6 half-life times (9 hours), everything is back close to equilibrium (0%).

Temperature

Reports the temperature in degrees Celsius or Fahrenheit.

A digital display with a black background. The word "TEMP" is in blue at the top. Below it, the number "18" is in green, and "°C" is in blue at the bottom right.

Diluent PPO2

The PPO2 of the currently selected diluent. Not measured directly, but calculated as the fraction of O2 in the diluent multiplied by the current depth's pressure.

Displays in **Flashing Red** when the PPO2 of the diluent is less than 0.19 or greater than 1.65.

When performing a manual diluent flush, you can check this value to see what the expected PPO2 will be at the current depth. Also, can use to verify it is safe to flush with the diluent.

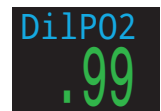

DilP02
.99



DilP02
1.77

Setpoint (SP)

The currently requested PPO2 setpoint.



SP
.7

Average PPO2

The purpose of this value is to show what PPO2 is actually being used for setpoint maintenance and decompression calculations.

The Petrel votes on the three measured PPO2 values to decide what is the most likely true PPO2. This value shows the result of the voting.

When you have bailed out to OC, the center row continues to display the external measured PPO2. Use this info display to see the OC PPO2.

In CC mode, displays in **Flashing Red** when less than 0.40 or greater than 1.6.



PP02
.36

In OC mode, displays in **Flashing Red** when less than 0.19 or greater than 1.65.



PP02
.16

Fraction Inspired O2 (FiO2)

The fraction of the breathing gas composed of O2. This value is independent of pressure.



FiO2
.42

CEIL

The current decompression ceiling in the current units (feet or meters) not rounded to the next deeper stop increment. (i.e. not a multiple of 10ft or 3m). **Flashes Red** if you ascend shallower than the current ceiling.



CEIL
17

GF99

The current gradient factor as a percentage (i.e. super-saturation percent gradient)

A digital display showing 'GF99' in blue text above '15%' in green text on a black background.

0% means the leading tissue super-saturation is equal to ambient pressure. Displays “On Gas” when tissue tension is less than the inspired inert gas pressure.

100% means the leading tissue super-saturation is equal to the original M-Value limit in the Bühlmann ZHL-16C model.

GF99 is displayed in **Yellow** when the current gradient factor modified M-Value (GF High) is exceeded.

GF99 is displayed in **Red** when 100% (un-modified M-Value) is exceeded.

SurfGF

The surfacing gradient factor expected if the diver instantaneously surfaced.

A digital display showing 'SurfGF' in blue text above '62%' in green text on a black background.

SurfGF colour is based on the current GF (GF99). If the current GF is greater than GF High, SurfGF will be displayed in **Yellow**. If the current gradient factor is greater than 100%, SurfGF will be displayed in **Red**.

@+5/TTS

“At plus 5” is the TTS if remaining at the current depth for 5 more minutes. This can be used as a measure of how fast you are on-gassing or off-gassing.

A digital display showing '@+5' in blue text above '20' in green text on a black background.

Since this value is most useful when compared to the current TTS, the current TTS is displayed beside the @+5 value.

Δ+5

The predicted change in TTS if you were to stay at the current depth for 5 more minutes.

A digital display showing 'Δ+5' in blue text above '+8' in green text on a black background.

A positive “Delta plus 5” indicates that you are on-gassing the leading tissue while a negative number indicates that you are off-gassing the leading tissue.

Dive End Time (DET)

This is similar to TTS but is expressed as a time of day.

A digital display showing 'DET' in blue text above '1:31' in green text on a black background.

The time of day at which you can expect to surface if you depart immediately, ascend at 10mpm or 33fpm, change gases when prompted, and perform all decompression stops as directed.

Gradient Factor

The deco conservatism value when the deco model is set to GF. The low and high gradient factors control the conservatism of the Bühlmann GF algorithm. See “Clearing up the Confusion About Deep Stops” by Erik Baker.



GF
30/70

VPM-B (and VPM-BG)

The deco conservatism value when the deco model is set to VPM-B. For VPM-B, higher values are more conservative.



VPM-B
+3

If the deco model is VPM-B/GFS, also displays the gradient factor for surfacing. For the gradient factor, higher values are less conservative.



VPM-BG
+3/90

Battery

The Petrel’s internal battery voltage. Displays in Yellow when the battery is low and needs replacement. Displays in Flashing Red when the battery is critically low and must be replaced as soon as possible. Also shows battery type.

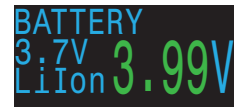

BATTERY
3.7V
LiIon 3.99V

External Battery (EXT V)

The voltage of the external battery used to fire the solenoid. Flashing Red when the battery is critically low and must be replaced as soon as possible.



EXT V
8.6V

Only sampled when solenoid is fired, so if solenoid has not yet fired, value is unknown and displays as a Yellow '?'.



EXT V
?

Pressure



The image shows a digital display with the word "MILLIVOLTS" in blue at the top. Below it, three green numbers are shown: "10.7", "10.5", and "11.0".

The pressure in millibars. Two values are shown, the surface (surf) pressure and the current (now) pressure. The current pressure is only shown on the surface.

Note that typical pressure at sea level is 1013 millibar, although it may vary with the weather (barometric pressure). For example, surface pressure may be as low as 980 millibar in a low pressure system, or as high as 1040 millibar in a high pressure system.

For this reason, the PPO2 displayed on the surface may not exactly match the FO2 (fraction of O2), although the displayed PPO2 is still correct.

The surface pressure is set based on the lowest pressure the dive computer sees in the 10 minutes prior to the start of a dive. Therefore, altitude is automatically accounted for and no special altitude setting is required.

The surface pressure is set when the Petrel is turned on. If the Altitude setting is set to SeaLvl, then surface pressure is always 1013 millibars.

Date and Time

In the format dd-mon-yy
12 or 24 hour clock time.



The image shows two side-by-side digital displays. Each has "DATE" and "TIME" in blue. The left display shows "28-Jun-15" and "16:31" in green. The right display shows "28-Jun-15" and "4:31pm" in green.

Serial Number & Version

Each Petrel has a unique serial number.

The version number indicates the available features. The last two numbers are the firmware version (V12 in this image).

TISSUES BAR GRAPH



The tissues bar graph shows the tissue compartment inert gas tissue tensions based on the Bühlmann ZHL-16C model. Note that VPM-B also tracks tensions in the same way.

The fastest tissue compartment is shown on the top, and the slowest on the bottom. Each bar is the combined sum of the nitrogen and helium inert gas tensions. Pressure increases to the right.

The vertical black line shows the inert gas inspired pressure. The boundary between the green and yellow zones is the ambient pressure. The boundary between the yellow and red zone is the ZHL-16C M-Value pressure.

Note that the scale for each tissue compartment above the green zone is different. The reason the bars are scaled in this way is so that the tissues tensions can be visualized in terms of risk (i.e. how close they are as a percentage to Bühlmann's original supersaturation limits). Also, this scale changes with depth, since the M-Value line also changes with depth.

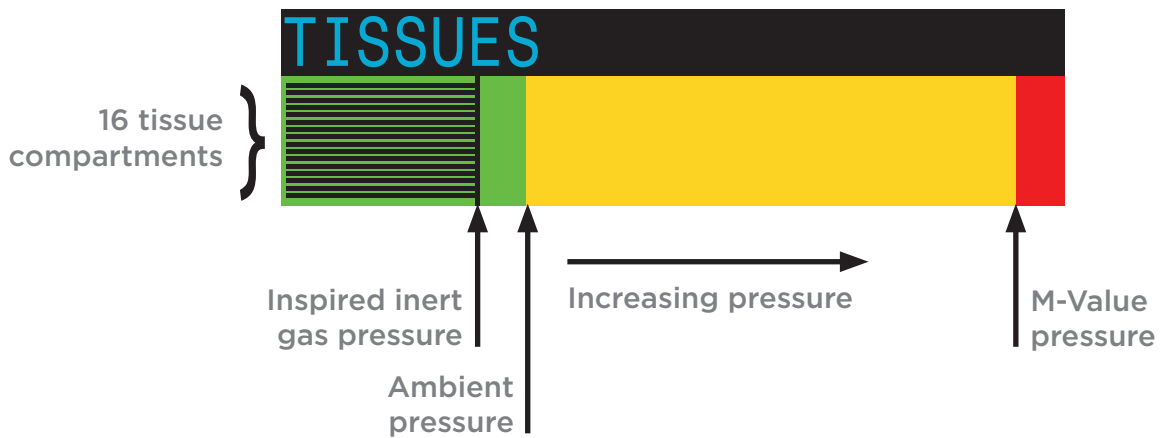

Sample Tissues Graphs



On surface (sat. with air)
 Note: Gas is 79% N₂ (21% O₂, or Air)



After descent



On-gassing



Deep stop



Last deco stop
 Note: Gas is now 50% O₂ and 50% N₂

5. Notifications

This section describes the different types of notifications the computer may present the diver.



Limitations Of Alarms

All alarm systems share common weaknesses.

They can alarm when no error condition exists (false positive). Or they can fail to alarm when a real error condition occurs (false negative).

Respond to alarms if you see them, but NEVER depend on them. Your judgment, education, and experience are your best defenses. Have a plan for failures, build experience slowly, and dive within your experience.

5.1. Types of Notifications

There are two types of notifications displayed by this dive computer. Primary notifications and persistent notifications.

Primary Notifications

Each primary notification displays as a message in yellow across the bottom row until dismissed.

The notification is dismissed by pressing either button.

For example, this “HIGH PPO2” message will appear if the average PPO2 goes above the high PPO2 limit for more than 30 seconds.

The highest priority notification is listed first. If multiple errors occur simultaneously, the notification with the highest priority will be displayed. Clear the first notification by pressing a button to see the next one.

If vibration alerts are on, the unit will vibrate when the alert first occurs and every 10 seconds until it is acknowledged.

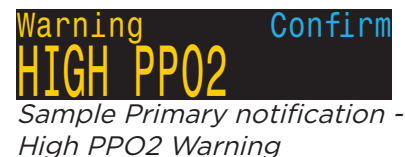

Persistent Notifications

Persistent notifications complement primary notifications, displaying while a dangerous condition is present until the condition is resolved.

Persistent notifications cannot be cleared while the condition that caused them persists.

Example: when PPO2 is in an unsafe range,

- Center row text that shows a “Low PPO2” or “High PPO2” message.
- PPO2 and gas values are highlighted and flash.

These persistent notifications will clear automatically once a safe PPO2 is restored.



*Sample "Low PPO2"
Persistent Notification*



*Sample "High PPO2"
Persistent Notification*

5.2. Vibration Alerts

In addition to visual notifications, the Petrel 3 has vibration alerts to help quickly notify the diver of warnings, errors and dive events.



Vibration is Battery Dependant

Vibration Alerts are only available when using a 1.5V Lithium or 3.7V Rechargeable Li-ion battery.

If turned on, attention vibration alerts occur when a safety stop starts, pauses, or is completed. Vibration alerts also occur any time a primary notification is triggered and every 10 seconds until it is acknowledged.

There are some persistent conditions, such as low PPO2 that will cause vibration to continue until the condition is resolved.

The vibration alert can be toggled on or off in System Setup > Alerts Setup , or in the Dive Setup menu.

A Test Vibration tool is also available in the Dive Setup menu and should be used regularly before diving to ensure the vibrator is functioning properly.



Caution

Although vibration alerts are very useful, never rely on them for your safety. Electromechanical devices can and will eventually fail.

Always be proactively aware of your depth, no-decompression limit, gas supply, and other critical dive data. You are ultimately responsible for your own safety.

5.3. List of primary notifications

The following table lists primary notifications you may see, their meaning, and steps to take to solve any problems.











If multiple warnings are triggered simultaneously, the notification with the highest priority will be displayed. Clear that notification by pressing any button to see the next notification.





Contact Shearwater

The subsequent list of notifications is not exhaustive. Please contact Shearwater if you experience any unexpected errors: info@shearwater.com

Display	Meaning	Action to take
Warning Confirm LOW PPO2	The PPO2 is below the limit set in the PPO2 limits menu.	Change your breathing gas to one safe for the current depth.
Warning Confirm HIGH PPO2	The PPO2 is above the limit set in the PPO2 limits menu.	Change your breathing gas to one safe for the current depth.
Warning Confirm MISSED DECO STOP	A required decompression stop was violated.	Descend deeper than the currently displayed stop depth. Monitor for symptoms of DCS. Use extra conservatism for future repetitive dives.
Warning Confirm FAST ASCENT	The ascent was sustained as faster than 10m/min (33ft/min)	Use a slow ascent rate. Monitor for symptoms of DCS. Use extra conservatism for future repetitive dives.
Warning Confirm LOW BATTERY INT	The internal battery is low.	Replace the battery.
Warning Confirm TISSUES CLEARED	The decompression tissue inert gas loading has been set to default levels.	Plan repetitive dives accordingly.
Warning Confirm VERY HIGH CNS	Central Nervous System (CNS) toxicity clock exceeded 150%	Switch to a gas with a lower PPO2 or ascend shallower (decompression ceiling allowing)

Display	Meaning	Action to take
	Central Nervous System (CNS) toxicity clock exceeded 90%	Switch to a gas with a lower PPO2 or ascend shallower (decompression ceiling allowing)
	NDL is less than low NDL alert value. (Only if alert active)	Ascend soon to avoid decompression obligation.
	Depth is deeper than depth alert value. (Only if alert active)	Ascend above depth limit.
	Dive time has surpassed time alert value. (Only if alert active)	End dive safely.
	No communications for 30 to 90 seconds.	See the Transmitter Connection Issues section for more information.
	No communications for 90+ seconds.	See the Transmitter Connection Issues section for more information.
	Low transmitter battery.	Replace the transmitter battery.
	Tank pressure exceeds rated pressure by more than 10%	Properly set the rated pressure in the AI Setup menu.
	Tank pressure has fallen below the critical pressure.	Be aware that gas is running low. Begin to end your dive and perform a controlled ascent to the surface.
	The computer has reset to recover from an unexpected software condition.	If this occurs more than once over a long period, please report to Shearwater Research Inc.

Display	Meaning	Action to take
	This reset shows up after a software update. This is the normal event that shows the computer has been rebooted after the software update.	N/A
	Firmware update failed, possibly due to a communications error or corrupted file.	Try the firmware upgrade again. Contact Shearwater if problem persists.

6. Compass

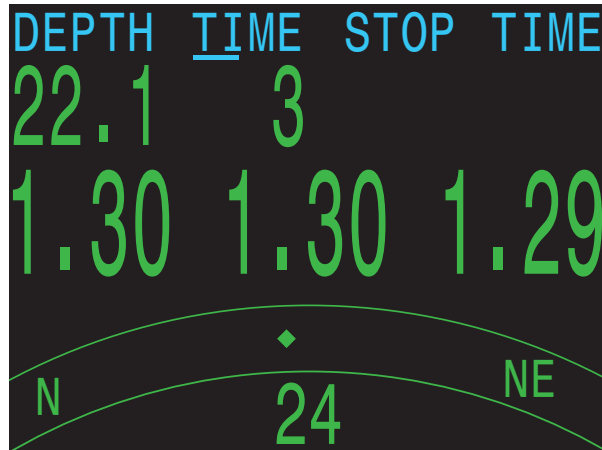

The Petrel 2 contains a tilt-compensated digital compass.

Compass features:

- 1° resolution
- $\pm 5^\circ$ accuracy
- Smooth, high-speed refresh rate
- User set heading marker with reciprocal
- True North (declination) adjustment
- Tilt compensation: $\pm 45^\circ$

Viewing the Compass

When enabled, the compass is viewed by pressing the SELECT (right) button once. Press SELECT again to continue on to view the regular info screens.

Unlike the regular info screens, the compass never times out back to the main screen. Pressing the MENU (left) button brings up the Mark Heading option. Pressing MENU again returns to the main screen.

Marking a Heading

To mark a heading, when viewing the compass press the MENU (left) button. This brings up the "Exit Mark" menu. Press the SELECT (right) button to mark the heading.



The marked heading is shown with a green arrow. When within $\pm 5^\circ$ of the heading, the degrees display turns green.



The reciprocal heading (180° from marked heading) is shown with a red arrow. When within $\pm 5^\circ$ of the reciprocal heading, the degrees display turns red.



When more than 5° off the marked heading, a green arrow shows the direction back to the marked heading. Also, the offset degrees to the heading are displayed (16° in the example image). This offset is useful when navigating patterns. For example, a box pattern requires turns at 90° intervals, while a triangle pattern requires 120° turns.



Compass Limitations

Calibration - The digital compass needs occasional calibration. This can be done in the **System Setup** → **Compass** menu.

Battery Changes - When the battery is changed, the compass requires calibration.

Interference - Since a compass operates by reading the Earth's magnetic field, the compass heading is affected by anything that distorts that field or creates its own. Steel objects and electric motors or cabling (e.g. from dive lights) should be kept at a distance. Being close to or inside a shipwreck may also affect the compass.

Magnetic declination (also called magnetic variation) is the difference between magnetic and True North. This can be compensated in the Compass Setup menu using the True North setting. The magnetic declination varies around the world, so will need to be readjusted when traveling.

Magnetic inclination (or magnetic dip) is how much the Earth's magnetic field points up or down. The compass automatically compensates for this angle. However, near the poles, the inclination angle can exceed 80° (i.e. the magnetic field points almost directly up or down), in which case the specified accuracy may not be met.

7. Air Integration

The Petrel 3 is equipped with 4-transmitter air integration capability.

This section covers operation of the AI feature.

AI Features

- Simultaneous wireless pressure monitoring of up to 4 tanks.
- Units in psi or bar.
- Logging of pressure
- Reserve and critical gas pressure warnings.



Shearwater Swift Wireless Transmitter

7.1. What is AI?

AI stands for Air Integration. On the Petrel 3, this refers to a system that uses wireless transmitters to measure the gas pressure in a SCUBA tank and transmit this information to the Petrel 3 dive computer for display and logging.

Data is transmitted using low-frequency (38kHz) radio frequency communications. A receiver in the Petrel 3 accepts this data and formats it for display.

The communication is one-way. The transmitter sends data to the Petrel 3, but the dive computer does not send any data to the transmitter.



Important EN 250 Certification Notes

The European EN 250 standard specifies minimum requirements for self-contained open-circuit compressed air underwater breathing apparatus and their sub-assemblies to ensure a minimum level of safe operation of the apparatus down to a maximum depth of 50 m.

Testing and validation of the Petrel 3 wireless air integration system for the EN 250 standard was only performed with the Shearwater Swift transmitter. Therefore, the Swift transmitter is the only officially compatible wireless pressure measurement accessory certified for use with the Petrel 3.

Under EN 250, the Petrel 3's air integration system is certified for use with air only to a maximum depth of 50 meters. Products marked EN 250 are intended for air use only. Products marked EN 13949 are intended for use with gases containing more than 22% oxygen and must not be used for air.

7.2. Basic AI Setup

This section will get you started with the basics of AI on the Petrel 3. Advanced setup and detailed descriptions will be covered in later sections.

Install the Transmitter

Before using the AI system, you will need to install one or more transmitters on a scuba tank first stage regulator.

The transmitter must be installed on a first stage port labeled “HP” (high pressure). Use a first stage regulator with at least two HP ports, so that a backup analog submersible pressure gauge (SPG) can be used.

Position the transmitter such that it is on the same side of your body as you wear your Petrel 3 handset. Range is limited to approximately 1 m (3 ft).

A high-pressure hose may be used to relocate the transmitter for better reception or convenience. Use hoses rated for a working pressure of 300 bar (4500 psi) or higher.

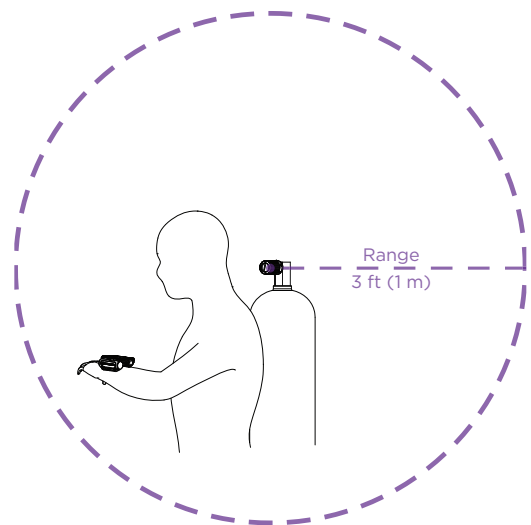
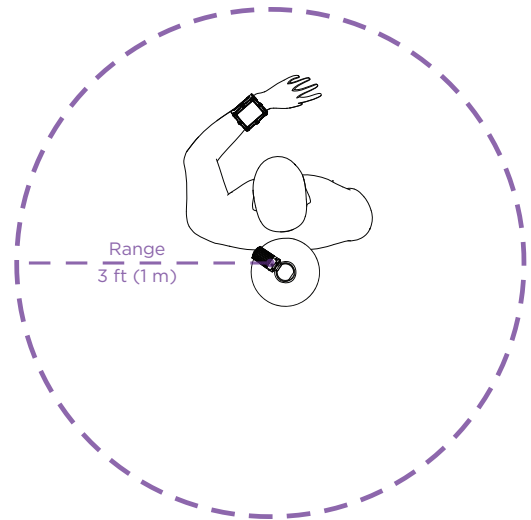

i **Some transmitters require a wrench (11/16" or 17mm) to tighten or loosen**

Avoid hand tightening or loosening unless otherwise specified by the transmitter manufacturer, as this may damage the transmitter.



The Shearwater Swift transmitter can be installed without tools.



Use a backup analog SPG

Always use a backup analog submersible pressure gauge as a redundant source of gas pressure information.

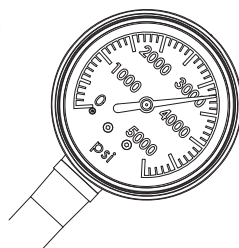

Install transmitter on 1st stage HP port
Install transmitter on the same side of your body as the handset. Range is approximately 3 feet (1 m).

Turn on the Transmitter

Turn on the transmitter by opening the tank valve. The transmitter will automatically wake up when it detects pressure.

Pressure data is transmitted approximately every 5 seconds.

Enable AI on the Petrel 3

On the Petrel 3, navigate to the System Setup > AI Setup. Change the AI Mode setting to On.

When AI Mode is set to Off, the AI sub-system is completely powered down and does not consume any power. When on, the AI system increases power consumption by approximately 10%.

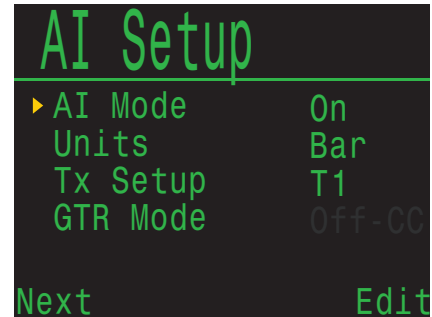

Note that AI is never on when the Petrel 3 is turned off.

Pair the Transmitter

Each transmitter has a unique serial number etched on its body. All communications are coded with this number so that the source of each pressure reading can be identified.

Pair the transmitter by going to the **Tx Setup** menu option, and selecting T1. Turn on T1, then enter the 6-digit transmitter serial number into the **T1 Serial #** setting. You only need to set this once, as it will be permanently saved in the settings memory.

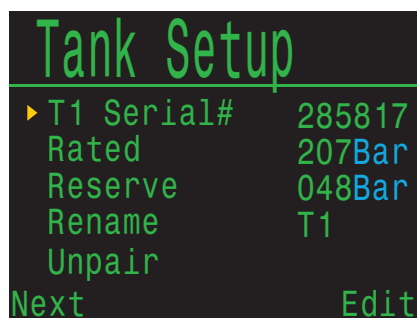
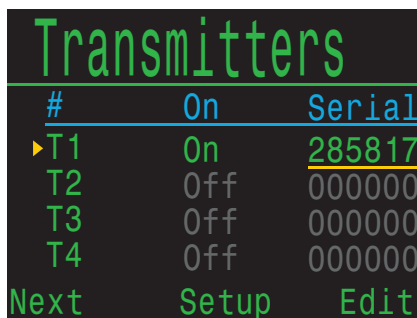



Check that your tank valve is open

Always take a few breaths from your regulator or purge your regulator's second stage while monitoring your tank pressure for a full 10-15 seconds prior to entering the water to ensure your tank valve is turned on.

If the first stage regulator is charged but the tank valve has been closed, the breathing gas available to the diver will decrease rapidly and within a few breaths the diver will face an "out of air" situation. Unlike an analog gauge, the air pressure reported on the Petrel 3 will only update every 5 seconds, so the pressure reported by the Petrel 3 must be monitored for longer than that (we suggest 10-15 seconds) to ensure the tank valve is open.

Including a regulator purge test followed by 10-15 seconds of air pressure monitoring before entering the water as part of your pre-dive safety check is a good way to mitigate this risk.

7.3. AI Displays

This section describes the display field types that are used to display AI information.

Tank Pressure Display

The pressure displays are the most fundamental AI displays, showing pressure in the current units (psi or bar).

At the top of each pressure display, a bar graph represents the pressure graphically. This bar graph is scaled from zero pressure up to the rated pressure setting. This is NOT a battery level indicator.

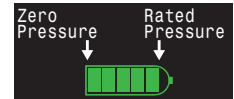

Tank pressure bar graph

Low Pressure warnings:



Reserve Pressure thresholds can be managed in the AI Setup Menu.

No Communication Warnings:

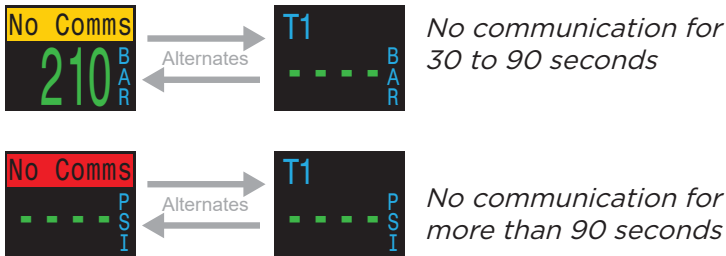

Low Transmitter Battery Warnings:

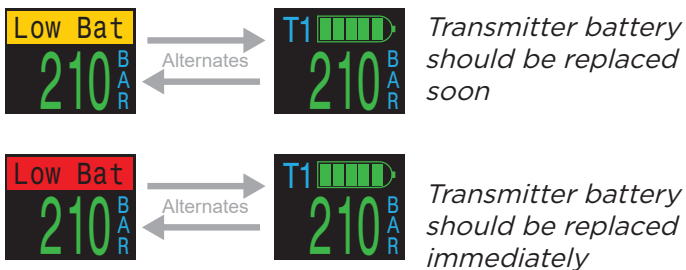

Renaming Transmitters

Transmitter titles can be customized in the transmitter setup menu. This makes it easier to keep track of which transmitter is reporting which cylinder pressure.

Each transmitter title has 2 characters that apply to all AI displays. The following options are available.

First Character: T, S, B, O, or D

Second Character: 1, 2, 3, or 4



Example of tanks labeled for bailout and deco

Renaming is for display purposes only. There is no relationship between a transmitter title and gas fraction for decompression calculation purposes.

7.4. Using Multiple Transmitters

When using multiple transmitters, best reception reliability will be attained by using transmitters with different transmission intervals or by using transmitters with active collision avoidance such as the Shearwater Swift Transmitter.

When two transmitters of the same transmission interval are used, the potential exists for their communication timing to become synchronized. When this occurs, data dropouts may result and could last up to 20 minutes or more.

Legacy Shearwater transmitters of different colors have different transmit timing. This reduces communication collisions that could potentially cause a loss of connection.

When using more than two transmitters, Shearwater recommends using the Swift transmitter which actively 'listens' for other transmitters in the vicinity and dynamically alters transmit timing to avoid interference.

There is no defined upper limit to the number of Swift transmitters that can be run concurrently. For more details, see the Swift Operating Instructions Manual.



Using Multiple Transmitters With The Same Transmission Interval May Result in Lost Comms

When using more than one transmitter, use transmitters with adaptive collision avoidance or legacy transmitters of different colors to prevent interference (see above).

7.5. Transmitter Connection Issues

If you are seeing “No Comms” errors, follow these steps:

If the “No Comms” is persistent:

- Check that the proper serial number is entered into the AI Setup Transmitter Setup menu.
- Ensure the Transmitter battery is not dead.
- Ensure the transmitter is turned on, by connecting it to a first stage and turning on the tank valve. Applying high pressure > 3.5 bar (50 psi) is the only way to turn on the transmitter.

The indicator light on a Swift transmitter will flash to indicate it is transmitting.

All compatible transmitters will power off after 2 minutes of no pressure.

- Bring the handset within range (1m / 3ft) of the transmitter. Having the transmitter too close (less than 5 cm / 2 inches) can also cause communication loss.

If the “No Comms” is intermittent:

- Search for sources of radio frequency (RF) interference, such as HID lights, scooters, suit heaters, or photo flashes. Try eliminating such sources to see if this solves the connection problem.
- Check the distance from transmitter to handset. If range related dropouts are occurring during diving, locating the transmitter on short length of high pressure hose is possible to decrease the transmitter to handset distance.
- If more than one legacy or compatible third party transmitter is in range of the computer, ensure that they have different transmit timings (grey vs. yellow coloured transmitters), to minimize interference. This is not usually a source of problems with Shearwater Swift transmitters.

8. Example Dives

8.1. Basic Setup

Before using the computer there are several things that need to be configured. This is not an exhaustive list of the pre-requisites for diving the system, but a suggestion of key tasks.

- **Calibrate the oxygen sensors if needed.** If calibration is not needed, then we recommend verifying the PPO₂ at multiple points. For example, in air, flushed with oxygen, and ideally also a PPO₂ greater than 1.0.
- In the System Setup menu **set the units** to metric or imperial, also set the date and time.
- **Enter the gases.** This includes the diluents (CC gases) and bailout gases (OC gases).
- The system will use the gases that are available in the order of oxygen content during the Time To Surface (TTS) prediction. The system will use the next available gas that has a PPO₂ of less than 1.0 for closed circuit diving.
- If the computer is in open circuit or is switched to open circuit during a dive, the system will calculate the TTS based on the configured open circuit gases that are available. It will use the next available gas that has a PPO₂ of less than 1.6 for open circuit diving.

NOTE: These gases are used automatically only for TTS predictions. The gas used to calculate the current tissue load and the current ceiling is always the gas actually selected by the diver.

8.2. Simple Example Dive

The following is a simple rebreather dive that includes decompression stops.

In this example:

Diluent: Air

Max Depth: 125 feet for 42 minutes

Dive Phase	Description	Petrel Display
On the Surface	The mode is set to CC and the diluent is set to air (21/00). Typically a PPO2 setpoint of 0.7 will be used at the surface. Never use the 0.19 PPO2 setpoint when breathing on the loop. It is for setup only!	
Descending	Once the descent has started the Petrel will change to dive mode. In dive mode dive time starts counting and the surface interval display changes to stop depth and time.	
Setpoint Switch	Press MENU to access the switch PPO2 setpoint menu. Then press SELECT to make the change. You can do this manually or have it switch automatically once you reach a certain depth.	
Reached Bottom	You've reached the bottom and can enjoy the fishies/wrecks/cave/mermaids. Remember to always monitor your PPO2. The NDl is showing that we have 11 minutes at this depth until decompression stops will be needed. The TTS of 4 minutes is the time to ascend directly to the surface at 33 ft/min.	

(Continued on next page)

(Continued on next page)

Dive Phase	Description	Petrel Display
Deco Needed	<p>Once the NDL hits 0, deco stops will be needed, which display in the top-right corner.</p> <p>Also, note that the NDL location is now displaying additional info, in this case @+5.</p> <p>TTS has increased to include deco stop time.</p>	
Ascending	<p>It is safe to ascend to 40ft. 2 minutes must be spent at this deco stop.</p> <p>While ascending, the bar graph to the right of the depth shows the ascent rate.</p> <p>Each bar indicates 10 ft per minute (3m/min) of ascent rate.</p>	
On Deco	<p>Stay at each stop depth until it clears.</p>	
Missed Deco Stop	<p>If you ascend shallower than the stop depth, the display will alarm.</p> <p>Acknowledge and clear the warning by pressing the SELECT button.</p> <p>Re-descend deeper than the stop depth to clear the flashing red text.</p>	
Deco Clear	<p>Once all the deco stops have cleared, you can ascend to the surface to end the dive.</p> <p>End of example.</p>	

8.3. Complex Example Dive

The following is a more complex rebreather dive that includes dive-planning and multi-gas OC bailout.

Diluent: Trimix (10/50)	Bailout gases: 10/50, 21/00, and 50/00
Max Depth: 90 meters for 20 minutes	Metric units (meters) are used

Dive Phase	Description	Petrel Display
Setup CC Gases	Best practices include checking your gas lists before each dive. This screen is available in the System Setup menu. For this dive the only CC diluent is trimix 10/50 (10% O2, 50% He, 40% N2).	
Setup OC Bailout Gases	For the OC bailout gas list, several gases are needed. We will verify that we are carrying enough of each gas when we plan the dive.	
Verify Settings	It is also prudent to ensure all other settings are correct before starting the dive. Although gases and some settings can be changed underwater, it is best to have them right from the start.	
Plan Dive & Bailout	Use the dive planner to check the total runtime, decompression schedule and bailout gas quantity needed. For CC dives, both the closed-circuit (CC) and bailout (BO) plans are displayed. The bailout plan also includes how much gas is needed. The on-board deco planner is limited in functionality, so for complex dives we recommend planning using desktop or smartphone dive planning software.	

(Continued on next page)

Complex CC Dive Example (continued)

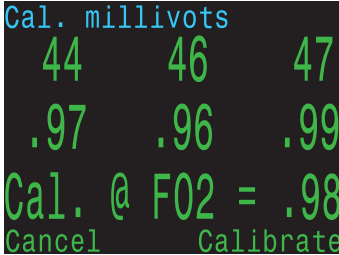
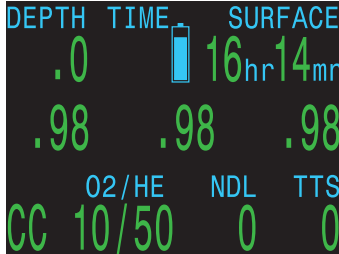
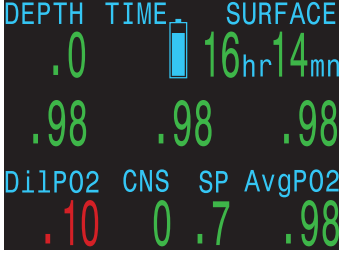
Dive Phase	Description	Petrel Display
PPO2 Calibration	<p>If the PPO2 sensors need calibration, follow the instructions from your rebreather manufacturer.</p> <p>On the PPO2 calibration screen, the top row displays the millivolt (mV) reading from each sensor. The middle row is the current PPO2 (from the last calibration). The bottom row shows the fraction of oxygen setting.</p> <p>After calibration completes a results screen will be displayed. Note that the PPO2 might not match the FO2 exactly, due to the ambient pressure not being exactly 1 ata.</p>	
Ready to Dive	<p>The dive is now ready to begin.</p>	
Note on Hypoxic Diluents	<p>Hypoxic diluents such as the 10/50 in this example require special training since they can be deadly near the surface. Pressing SELECT brings up the first info screen which shows the diluent PPO2. The red indicates it is unsafe to breathe directly.</p> <p>You can view this info at any time to verify that the diluent is safe or to check what the expected PPO2 will be when flushing with diluent at depth.</p>	





(Continued on next page)

Complex CC Dive Example (continued)

Dive Phase	Description	Petrel Display
Decreasing NDL	As we descend, the NDL decreases. The TTS shows it will take 5 minutes to ascend to the surface at 10m/min (33ft/min).	<pre> DEPTH TIME STOP TIME 48.4 3 1.30 1.29 O2/HE NDL TTS CC 10/50 4 5 </pre>
Bottom Time	We have now completed the bottom time. The TTS indicates we have about 1.5 hours (92 minutes) of decompression to do. The first stop will be at 48m for 1 minute.	<pre> DEPTH TIME STOP TIME 90.2 20 48 1 1.30 1.30 1.29 O2/HE GF99 TTS CC 10/50 On 92 Gas </pre>
Ascending to First Stop	Here we are ascending at 3m/min (each bar beside the depth is 3m/min). This is slower than the expected 10m/min ascent rate. This slow ascent has caused the TTS to rise, as most tissues are still on-gassing.	<pre> DEPTH TIME STOP TIME 61.6 29 48 1 1.29 1.28 1.29 O2/HE GF99 TTS CC 10/50 6% 96 </pre>
First Deco Stop	The slow ascent has caused the first stop to clear before we reached it. This often happens with slow ascents. Note that the GF99 value now indicates that the leading tissues are now off-gassing. However, at this deep depth most tissue compartments are still on-gassing.	<pre> DEPTH TIME STOP TIME 45.3 34 45 1 1.30 1.32 1.31 O2/HE GF99 TTS CC 10/50 20% 98 </pre>
A problem has developed	The yellow cell reading is disagreeing with the other two. A flush with diluent has shown that the lone low cell is actually correct. It is decided to bailout to open circuit.	<pre> DEPTH TIME STOP TIME 30.4 42 30 2 .41 1.05 1.08 O2/HE GF99 TTS CC 10/50 45% 89 </pre>

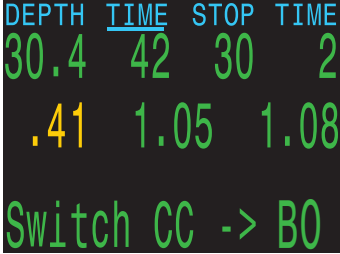
(Continued on next page)

Complex CC Dive Example (continued)

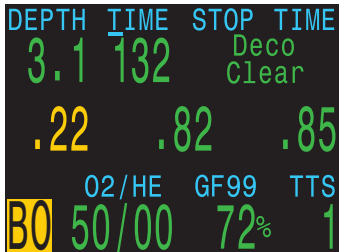
Dive Phase	Description	Petrel Display
Bailout	<p>After physically switching the BOV or mouthpiece, the computer needs to be set to BO mode for proper deco calculations.</p> <p>Two presses on MENU brings up the "SWITCH CC -> BO" menu. Pressing SELECT makes the change.</p> <p>Note that the loop PPO2 continues to display. This is important in case the diver later needs to go back onto the loop. Also note that "BO" is displayed in yellow to indicate the bailout condition.</p> <p>The best BO gas was automatically selected, and the deco schedule has been adjusted based on the BO gases.</p>	 
Switch Gas	<p>We are now at 21m, having completed a few more deco stops. The gas is now displaying in yellow, indicating a better gas is available.</p> <p>Pressing MENU twice brings up the "SELECT GAS" menu, and pressing SELECT enters it. With the "new style" gas select menu, the best gas will already be the initial selection, just press SELECT to make it the active gas.</p> <p>If using the "old style" gas select menu, see the gas select section for instructions.</p>	 
Deco Clear	<p>Follow the deco stops until they have all cleared. Now it is time to ascend and end the dive.</p> <p>End of example.</p>	

9. Decompression and Gradient Factors

The basic decompression algorithm used for the computer is Bühlmann ZHL-16C. It has been modified by the use of Gradient Factors that were developed by Erik Baker. We have used his ideas to create our own code to implement it. We would like to give credit to Erik for his work in education about decompression algorithms, but he is in no way responsible for the code we have written.

The computer implements Gradient Factors by using levels of conservatism. The levels of conservatism are pairs of number like 30/70. For a more detailed explanation of their meaning, please refer to Erik Baker's excellent articles: **Clearing Up The Confusion About "Deep Stops"** and **Understanding M-values**. The articles are readily available on the web. You might also want to search for "Gradient Factors" on the web.

The default of the system is 30/70. The system provides several settings that are more aggressive than the default.

Don't use the system until you understand how it works.

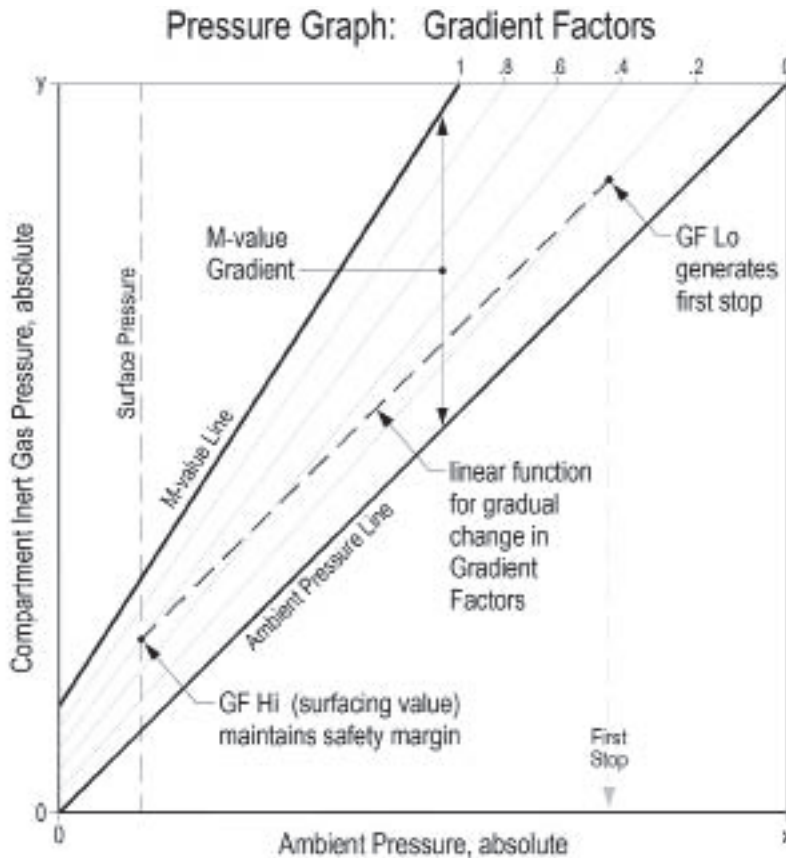

A Gradient Factor is simply a decimal fraction (or percentage) of the M-value Gradient.

Gradient Factors (GF) are defined between zero and one, $0 \leq GF \leq 1$.

A Gradient Factor of 0 represents the ambient pressure line.

A Gradient Factor of 1 represents the M-value line.

Gradient Factors modify the original M-value equations for conservatism within the decompression zone.

The lower Gradient Factor value (GF Lo) determines the depth of the first stop. Used to generate deep stops to the depth of the "deepest possible deco stop."

Graph from Erik Baker's "Clearing Up The Confusion About Deep Stops"

9.1. Decompression information accuracy

Decompression information displayed by this computer, including NDL, stop depth, stop time, and TTS are predictions. These values are continuously recalculated and will change with changing conditions. The accuracy of this information is dependent on several assumptions made by the decompression algorithm. It is important to understand these assumptions to ensure accurate decompression information.

It is assumed that the diver's ascent rate is 10m/min. Ascending significantly faster or slower than this will impact decompression obligations. It is also assumed that the diver is carrying and plans to use every gas that is currently turned on. Leaving gasses that are not expected to be used turned on will result in inaccurate time to surface, decompression stop and decompression time information being displayed.

On ascent, it is assumed that the diver will perform decompression stops using the gas with the highest PPO₂ below the OC Deco PPO₂ value (default 1.61). If there is a better gas available, the current gas will be displayed in yellow, indicating that a gas change is expected. The decompression prediction displayed always assumes that the best gas will be used. Even if the switch to a better gas has not been completed yet, decompression predictions will be displayed as if the switch is about to occur in the next 5 seconds.

Divers can encounter longer than expected decompression stops as well as inaccurate time to surface predictions if they fail to switch to a better gas when prompted by the computer.

Example: A diver on a decompression dive to 40m/131ft for 40 minutes with GF settings of 45/85 has two gasses programmed into their computer and turned on: 21/00 & 99/00. The diver's decompression schedule will be calculated based on breathing 21% oxygen for the decent, bottom and ascent phases of the dive until the diver ascends to 6m/20ft. At 6m/20ft the PPO₂ of the 99/00 mix is 1.606 (less than 1.61), so it is the best decompression gas available.

Decompression information for the remaining stops will be calculated and displayed assuming the diver is going to switch to this better gas. This dive profile indicates these stops would be 8 minutes at 6m/20ft and 12 minutes at 3m/10ft. If the diver never makes the switch to 99/00, the computer will not allow them to surface until adequate off-gassing has occurred, but it will continue to assume the diver is about to make the gas switch and the decompression times given will be grossly inaccurate. The 6m/20ft stop will take 19 minutes to clear and the 3m/10ft stop will take 38 minutes to clear. That is a total time to surface difference of 37 minutes.

In a lost gas scenario or in the event a diver forgets to turn off a gas they are not carrying before a dive, gasses can be turned off during the dive in the Dive Setup -> Define Gas menu.

10. Menus



Press MENU (left) button to step through the menus.

Press SELECT (right) button to execute command or enter sub-menu.

Menus display on the bottom row.

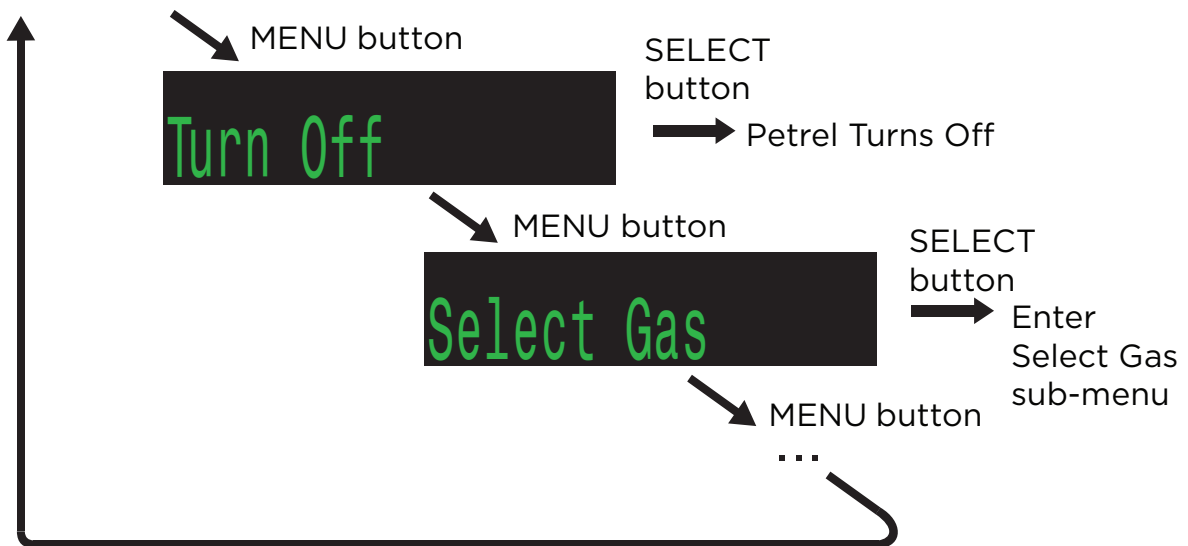

Menus perform actions and allow settings to be changed.

Starting from the main screen, pressing the MENU (left) button steps through the menus. When all menus have been viewed, pressing MENU again will return to the main screen.

Pressing the SELECT (right) button when a menu is displayed, either performs that action or enters a sub-menu.

If no buttons are pushed for 1 minute, the menu system will time-out, returning to the main screen. Anything that had been previously saved will be retained. Anything that was in the middle of editing will be discarded.

Adaptive Menu

Only menus necessary for the current mode are shown. This keeps operation simple, prevents mistakes, and reduces button presses.

10.1. Menu Structure

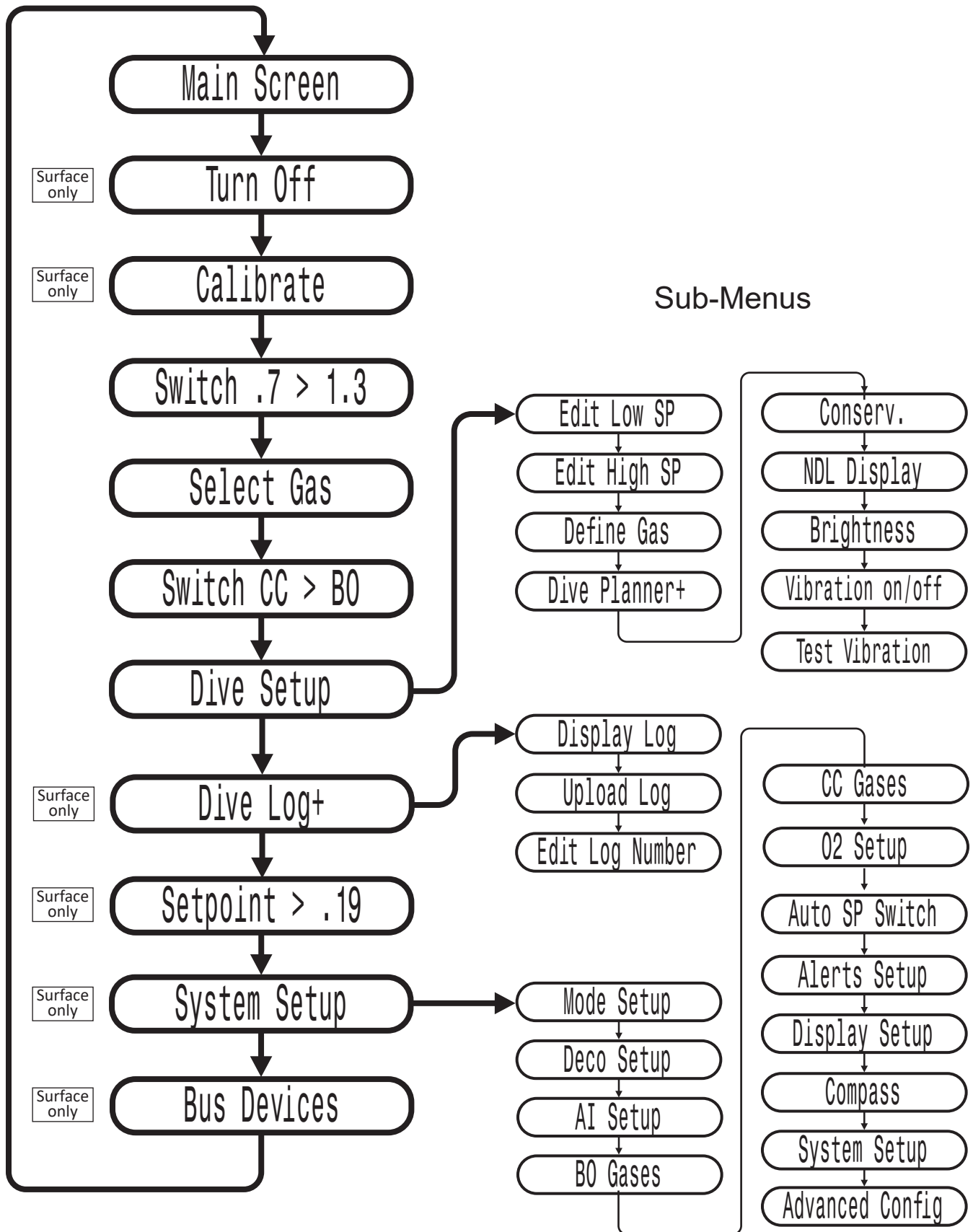

10.2. Menu Reference

10.2.1. Turn Off

The “Turn Off” item puts the computer to sleep. While sleeping, the screen is blank, but the tissue contents are maintained for repetitive diving. The “Turn Off” menu item will not appear during a dive. It will also not appear after a dive until the End Dive Delay time has expired to allow for a continuation dive.



10.2.2. Calibration

The Calibrate menu will only appear when in CC mode and on the surface. This menu calibrates the mV output from the oxygen sensors to PPO2.

Upon selecting the calibration menu, the screen will show:

- Top row: Millivolt (mV) readings from the 3 O2 sensors.
- Middle row: PPO2 values (using the previous calibration).
- Bottom row: The calibration gas fraction of O2 (FO2).

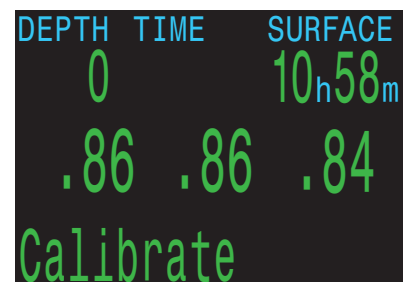

If you need to change the calibration gas FO2, do this in the System Setup → O2 Setup menu.

After flooding the breathing loop with the calibration gas (typically pure oxygen), press the SELECT button to perform the calibration.



Good sensors should be in the range of 35 - 65 mV at sea level in 100% oxygen. A sensor will fail calibration if not in the range of 30mV to 70 mV. This allowable range scales automatically with changes to FO2 and barometric pressure. If outside the allowable range, a millivolt reading is shown in yellow.

Once the calibration completes, a report will be shown. This shows which sensors passed calibration, and the value of the expected PPO2 based on barometric pressure and the FO2.



Back at the main screen, the displays should now all read the expected PPO2. For example, if FO2 is 0.98 and barometric pressure is 1013 mbar (1 ata), then PPO2 will be 0.98. If any display shows **FAIL**, the calibration has failed because the mV reading is out of range.

The “Calibrate” menu item will not display during a dive.

10.2.3. Calibration Problems

One sensor displays FAIL after calibration

This could indicate a bad sensor. It has failed because the mV output was not in range. The sensor could be old or damaged, and should be inspected. Damage and corrosion to wires or connectors is also a common problem. Fix the problem and recalibrate before diving.



All sensors display FAIL after calibration

This could be caused by an accidentally unplugged cable or a damaged cable or connector. Also, accidentally performing the calibration in air or without a proper oxygen flush could cause this problem. A failed calibration can only be fixed by performing a successful calibration.



PPO2 does not show 0.98 after calibration

If the Altitude setting in the Display Setup menu is set to Auto, then the PPO2 after calibration may not be exactly equal to the FO2.

This is because weather causes minor changes in barometric pressure. For example, say a low-pressure weather system has reduced the normal (1013mbar) barometric pressure to 990mbar. The PPO2 in absolute atmospheres is then $0.98 * (990/1013) = 0.96$.



The 0.96 PPO2 result is, in this case, correct. At high altitudes, the difference between FO2 and PPO2 will be even larger. To see the current pressure, start at the main screen and press the SELECT button a few times (displays as Pressure mBar NOW).

If you are at sea level, and want the calibrated PPO2 to exactly match the FO2, then change the Altitude setting to SeaLvl. Only do this when actually at sea level, and also be aware that using this SeaLvl setting is actually introducing error into the PPO2 measurements.



10.2.4. Switch Setpoint

During a dive the “Switch Setpoint” menu item will be the first item displayed, since the “Turn Off” and “Calibrate” displays are disabled when diving.

Pressing SELECT when this menu is displayed changes the PPO2 setpoint from the low setpoint to the high setpoint or vice-versa. To redefine the PPO2 value of a setpoint, use the Dive Setup menu.



This menu item performs a manual switching of PPO2 setpoint. Automatic setpoint switching can be setup in the System Setup > Auto SP Switch menu. When auto setpoint switches are enabled, this menu item is still available to provide manual control.

10.2.5. Select Gas

This menu item allows you to pick a gas from the gases you have created. The selected gas will be used either as the breathing gas in open circuit mode, or the diluent in closed circuit mode.

Gases are always sorted from most to least oxygen content.

Use the MENU button to increment to the desired diluent/gas, then press the SELECT button to select that diluent/gas.

If you increment past the number of gases available, the display will fall back out of the “Select Gas” display without changing the selected gas.

An ‘A’ will appear next to the currently active gas.

A gas that is off will be shown in magenta, but can still be selected. It will be turned on automatically if it is selected. Off gases are not used in decompression calculations.

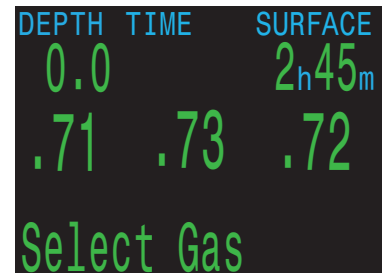

Select Gas main menu



Gas 1, Active Gas, 21% O2



Gas 2, Turned on, 50% O2



Gas 3, Turned Off, 18% O2, 50% He

10.2.6. Radio Station Gases



For computer models that support open circuit and closed circuit operation, the system maintains two sets of gases - one for open circuit and one for closed circuit.

The way they operate is very similar to the way car radios work with AM and FM stations.

When you are listening to an FM station and you push a station selection button, it will take you to another FM station. If you add a new station, it will be an FM station.

Similarly, if you are in the AM mode, adding or deleting a station would add or delete an AM station.

With radio station gases, when you are in open circuit, adding, deleting or selecting a gas will refer to an open circuit gas. Just like the FM stations are selected when your radio is in FM mode, the closed circuit gases are available in the closed circuit mode. When you switch to open circuit, the gases available will be open circuit gases.



Gases will not turn off automatically

Selecting a new gas will turn that gas on if it is off, but gases will never turn off automatically.

It is important to turn off all gases you are not carrying and or do not plan to use on the dive in the Define Gas menu to ensure you receive accurate decompression information.

10.2.7. Select Gas Menu Styles

Two styles of Select Gas menus are available, Classic and New.

Change between the two styles in the Adv. Config 1 menu.

Classic Style Select Gas

The classic Select Gas style is as described on the previous page.

- One gas is shown at a time.
- Press MENU to step through gases, and SELECT to select the shown gas.
- Gases are sorted from highest O2% to lowest O2%.
- Stepping past the last gas will exit the menu without changing the active gas.
- Upon entering the Select Gas menu, the first gas shown is always the highest O2% gas.

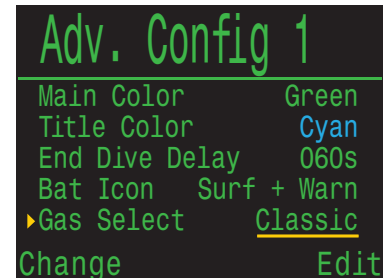

Gas select menu style changed in Adv. Config 1



Classic style gas select menu

New Style Select Gas

The new style makes visualizing the gas list easier. It also reduces button presses for deco gas switches.

- Shows all gases on the screen at once.
- Press MENU to step through gases, and SELECT to select the pointed to gas.
- A gas must be selected to exit the menu (scrolling past last gas wraps back to first gas).
- The active gas is shown with a green background.
- Turned off gases are shown in magenta (purple).
- Gases are sorted from highest O2% to lowest O2%.
- When diving and there is a deco stop, the first gas pointed to will be the most appropriate gas (highest PPO2 less than 1.61). This reduces button presses in most cases.
- On the surface or when no deco stops are needed, the first gas pointed to will be the active gas.

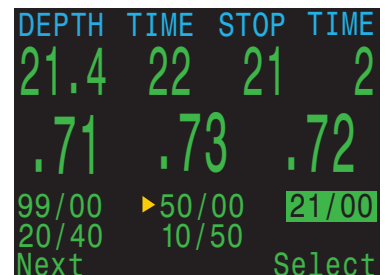

New style gas select menu layout. 5 gases currently programmed and on



50% O2 turned off. Select to change to 50% and turn gas on



21% O2 is currently active gas, Select to exit menu making no changes.

10.2.8. Switch to CC/BO

Depending on the current computer setting, this selection will show as either “Switch CC > BO” or “Switch BO > CC”.

Pressing SELECT will select the displayed mode for decompression calculations. When switching to Bailout while diving, the most appropriate open circuit gas will become the breathing gas for calculations.

At this point, the diver may want to switch to a different gas, but since the diver may have other things to deal with, the computer will make a “best guess” of which gas the diver would choose.

External PPO2 sensors readings will continue to be displayed so the user can monitor their loop PPO2 in case they need to return to the loop.



10.2.9. External PPO2 Monitoring

This system is connected to three sensors inside the rebreather. The PPO2 input from these sensors is used to determine the system average PPO2 which is used to govern solenoid injections and for decompression calculations and CNS tracking.

A voting algorithm is used to decide which of the three sensors are likely to be correct. If a sensor matches either of the other two sensors within $\pm 20\%$, it passes voting. The system average PPO2 is the average of all sensors that have passed voting.

For instance, in the example above, sensor 1 has failed voting. The PPO2 is displayed in yellow to show that it has failed voting. The system average PPO2 is the average PPO2 of sensor 2 and 3.

If all sensors fail voting, then the display will alternate VOTING FAILED with the PPO2 measurements (which will all be yellow to indicate that voting has failed). When voting has failed, while still in closed circuit mode, the lowest PPO2 reading will be used for deco calculations (i.e. the most conservative value).

10.2.10. Setpoint -> .19

Pressing SELECT when this menu is displayed changes the PPO2 setpoint to 0.19. This menu is only available when on the surface.

This feature is provided as a convenience to prevent the solenoid from firing when setting up the rebreather on your workbench. There is very little room for error with a 0.19 setpoint, so it should never be used when breathing on the loop.

If a dive begins on the 0.19 setpoint, the setpoint is automatically switched up to the low setpoint.

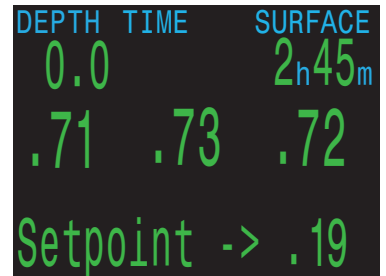

Set Setpoint to 0.19



Save your life! NEVER breath on the loop when setpoint is 0.19

There is very little room for error with a 0.19 PPO2 setpoint. A small drop in PPO2 could lead to hypoxia, which is a leading cause of rebreather fatalities and can be just as deadly on the surface as underwater.

The 0.19 setpoint is only for use during setup and transportation.

10.3. Dive Setup

All of the Dive Setup menus are available both on the surface and when diving.

The values in Dive Setup can also be accessed in the Systems Setup menu, but the System Setup menu is not available when diving.

Pressing the right (SELECT) button will enter the Dive Setup sub-menu.

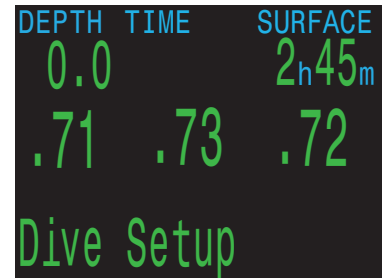

Menu appearance in BO mode

10.3.1. Edit Low Setpoint

This item allows you to edit the low setpoint value. Initially it will display the currently selected value.

Press the right (Edit) button to open the edit display. Press the left (Change) button to increment the setpoint.

Values from 0.4 to 1.5 are allowed. Incrementing past 1.5 returns the value to 0.4. Press the right (Save) button to lock in new low setpoint.



Edit Low Setpoint option shows current setpoint



Press the Change button to increment the setpoint

10.3.2. Edit High Setpoint

Works in exactly the same way as the Edit Low Setpoint function above.



Edit High Setpoint menu

10.3.3. Define Gas

The define gas function allows you to set up 5 gases in Closed Circuit and 5 gases in Open Circuit. You must be in Bail Out mode to edit open circuit gases, and you must be in Closed Circuit to edit closed circuit diluents. For each gas, you can select the percentage of oxygen and helium in the gas. The remainder is assumed to be nitrogen.

Pushing the right (Define) button presents the function to define gas number 1.

The left (Next) button increments to the next gas.

Press the right (Edit) button to edit a gas.

The first option is to toggle the gas on or off as indicated by the underline. Use the left (Change) button to toggle the gas on.

Continuing along, the gas contents are edited one digit at a time. The underline shows the digit being edited.

Each push of the left (Change) button increments the digit being edited. When the digit reaches 9, it will roll over to 0.

Pushing the right button (Next) will lock in the current digit, and move on to the next digit.

A helpful indicator of what is being edited is included in the center at the bottom.

Pushing the right (Save) button on the last digit will finish editing that gas, and bring you back to the gas number. You can continue to increment through the gases pressing the left (Next) button.

The “A” denotes the active gas. You cannot turn off the active gas in the Define Gas menu. If you try, it will generate an error. You can edit it, but cannot set both the O2 and HE to 00.

Setting any gas to 00/00 will automatically turn it off.

The computer will display all 5 gas entries available to allow you to enter new gases.

Pressing MENU one more time when the fifth gas is displayed will return you to the “Define Gas” menu item.

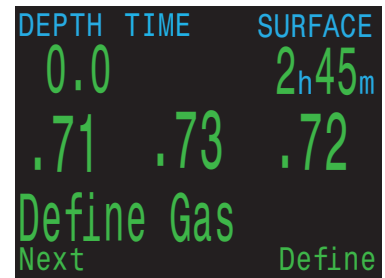

Define Gas Menu



Press Next to increment to next gas



Press Edit to modify this gas



Press Change to toggle gas on



Press Next to move on to edit gas contents



Press Change to increment underlined digit



The “He%” indicator shows we are editing the fraction of helium



Press Save after editing the last digit



The “A” denotes the currently active gas

10.3.4. New Style Define Gas

Similar to the New Style Select Gas menu, the New Style Define Gas menu shows all gases on the screen at once at the expense of font size.

If the Gas Select style is set to New, the computer will also display the New Style Define Gas Menu.

When the Define Gas menu is opened, all of the gases will be displayed. Turned on gases will be in green, turned off gases will be magenta, and the currently active gas will be highlighted.

Press the left (Next) button until the arrow points to the gas you would like to edit, then press the right (Edit) button.

Similar to the Classic Style Define Gas menu, the attribute being toggled is displayed at the bottom of the display.

Gases can be toggled on or off, and the gas fractions of oxygen and helium can be changed one digit at a time.

When you are finished editing move the arrow to the Exit option and press the right (Exit) button to leave the define gas menu.

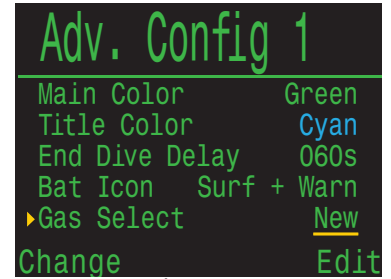

Set Gas Select to "New" in Adv.1 to use New Style Define Gas menu

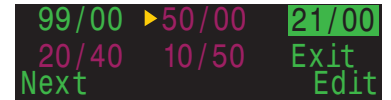

Press Next to increment to next gas



Press Change to toggle the gas on

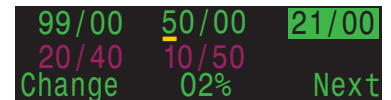

Press Change to increment gas fraction one digit at a time

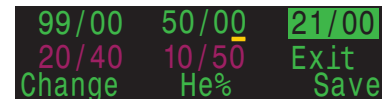

Press Save when finished editing the last digit

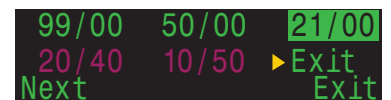

Select the Exit item to leave the Define Gas Menu when finished



Turn off gases you are not carrying

Only turn on the gases you are actually carrying and plan to use on the dive. Failure to abide by this warning may result in inaccurate decompression information being displayed.

With radio station gases, the computer has a full picture of the OC and CC gases you are carrying and can make informed predictions about decompression times. There is no need to turn gases off and on when you switch from CC to OC, because the computer already knows what the gas sets are. You should only have the CC and OC gases you are actually carrying turned on.

If you often use other gases, you can enter the gas and turn it off. You can turn gases on and off during a dive and you can also add or remove a gas during the dive if needed.

10.3.5. Deco Planner

Introduction

Calculates decompression profiles for simple dives.
Calculates gas consumption based on RMV
Can be used both on the surface and during a dive.



Setup

The planner uses the current gases programmed in the current dive mode, as well as the current conservatism (GF low/high) settings. VPM-B dive planning is available on units with the optional VPM-B unlock.



Deco Planner Limitations

The Petrel 3's Deco Planner is intended for simple dives.

Multi-level dives are not supported.

The Deco Planner does not provide thorough validation of the profile. For example, it does not check for nitrogen narcosis limitations, gas usage limitations, or CNS percentage violations.

The user is responsible for ensuring a safe profile is followed.



Important!

The Petrel 3's Deco Planner makes the following assumptions:

- Descent rate is 18m/min (60ft/min) and the ascent rate is 10m/min (33ft/min).
- The gas in use at any time will be the gas with the highest PPO₂ within the PPO₂ limits.
- The planner will use the configured last stop depth.
- The RMV is the same during the bottom phase of the dive as it is while traveling and during deco

When used at the Surface

Enter the dive bottom depth, bottom time, respiratory minute volume (RMV) and PPO2.

Note: Residual tissue loading (and CNS%) from recent dives will be used in calculating the profile

When the correct values are entered, confirm decompression settings and starting CNS, then select “Plan”.

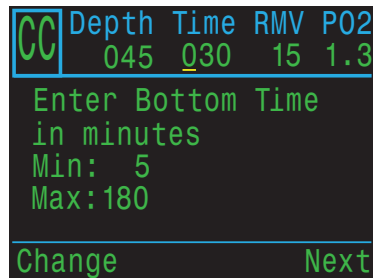

Enter dive details

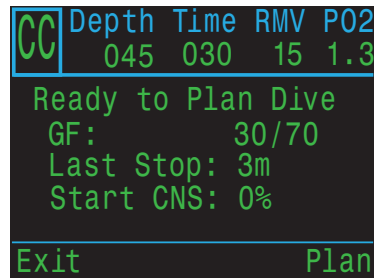

Press Plan when ready

When used during a dive

Computes the decompression profile assuming the ascent will begin immediately. There are no settings to enter. (RMV is last used value).

Result Screens

The results are given in tables showing:

Stp:	Stop Depth	In meters or feet
Tme	Stop Time	In minutes
Run	Run Time	In minutes
Gas	Gas Used	%O2 / &He
Qty	Quantity Used	In liters or Cuft

The first few rows will show the bottom time (bot) and the ascent time (asc) to the first stop. Multiple initial ascent legs may be shown if gas switches are needed.

If there are too many stops to display, the results will be split onto several screens.

A bailout plan based on the programmed bailout gases will automatically be generated after the closed circuit deco summary.

CC	Depth	Time	RMV	P02
	045	030	15	1.3
Stp	Tme	Run	Gas	
45	bot	30	10/50	
21	asc	33	10/50	
21		1	34	10/50
18		2	36	10/50
15		2	38	10/50
Quit				Next

Closed circuit deco plan page 1

BO	Depth	Time	RMV	P02
	045	030	15	1.3
Stp	Tme	Run	Gas	Qty
6	6	53	99/00	242
3	11	64	99/00	212
Quit				Next

Bailout deco plan page 2

After the last page of the deco schedule, bailout gas usage and deco summary screens show the expected quantity of each gas used for the dive, the total dive time, the time spent on deco and final CNS%.

BO	Depth	Time	RMV	P02
	045	030	15	1.3
Gas Usage, in Liters				
	99/00:	453		
	50/00:	410		
	21/25:	260		
Quit				Next

Open circuit gas usage summary

CC	Depth	Time	RMV	P02
	040	020	15	1.3
CC Summary				
	Run:	65 minutes		
	Deco:	35 minutes		
	CNS:	36 %		
Quit				Next

Open circuit deco summary

If no decompression is required, no table will be shown. Instead, the total No-Decompression-Limit (NDL) time in minutes, at the given bottom depth will be reported. Also, the gas quantity required to surface (bailout in CC) will be reported.

CC	Depth	Time	RMV	P02
	024	030	14	1.3
No Deco Stops.				
Total NDL at 24m is 30 minutes				
Bailout gas quantity is 73 Liters.				
Quit				Done

No decompression required

10.3.6. Conservatism

The conservatism settings (GF High and GF Low) can be edited in the Dive Setup menu.



Conserv. 30/70
Next Edit

While diving, only the GF High value can be edited. This allows changing the surfacing conservatism during a dive. For example, if you worked much harder on the bottom segment than expected, you may wish to add conservatism by reducing the GF High setting

10.3.7. NDL Replacement Display

While in decompression, NDL is 0. This makes the NDL area wasted space until decompression is cleared.



NDL Display CEIL
Change Save

The NDL Display option allows you to replace the NDL with different information once decompression is required and the NDL has gone to 0.

The NDL display option can be changed during the dive through the dive setup menu.

There are 6 options for NDL Display:

1. NDL
2. CEIL
3. GF99
4. SurfGF
5. @+5
6. Δ+5

10.3.8. Brightness

The display brightness has four fixed brightness settings plus an Auto mode.

The fixed options are:

- Cave: Longest battery life.
- Low: Second longest battery life.
- Med: Best mix of battery life and readability.
- High: Easiest readability, especially in bright sunlight.

Auto will use the light sensor to determine the brightness of the display. The more ambient light there is, the brighter the display will get. At depth, or in dark water, very little brightness is needed to see the display.

The Auto setting works well in most situations.

The brightness of the display is the major determinant of battery life. Up to 80% of the power consumption is to power the display. When a low battery alert occurs, the display brightness is automatically reduced to extend battery life.

10.3.9. Vibration On/Off

Shows current state of vibration function. Press the right (Edit) button to toggle the vibration function on or off.



10.3.10. Test Vibration

Press the right (Ok) button to quickly test the vibration function to ensure it's working correctly.

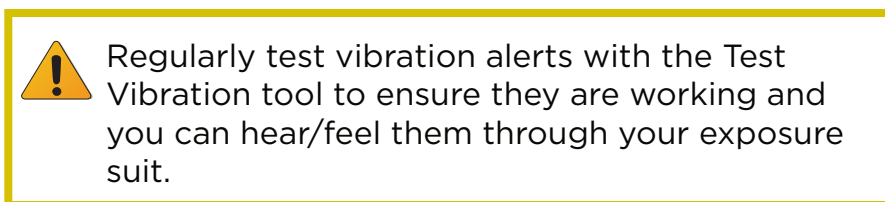

10.4. Dive Log

Use the Dive Log menu to review logs stored on the Petrel 3. Up to 1000 hours of detailed logs can be stored at the default sampling rate of 10 seconds.



The Dive Log menu is only available when on the surface.

10.4.1. Display Log

Use this menu to display a list of logged dives and view details. Select a dive to view from the Dive log list.



The profile of the dive is plotted in blue, with decompression stops plotted in red. The following information is displayed by scrolling through the dive log screens:



- Maximum and Average depth
- Dive number
- Date (dd-mon-yyyy)
- Start - Time of day dive started
- End - Time of day dive ended
- Length of dive in minutes
- Minimum, maximum, and average temperature
- Dive mode (Air, Nitrox, etc.)
- Surface interval preceding the dive
- Recorded Surface Pressure at the beginning of the dive
- Gradient factor settings used
- Start and end CNS
- Start and end pressure for up to 4 AI transmitters

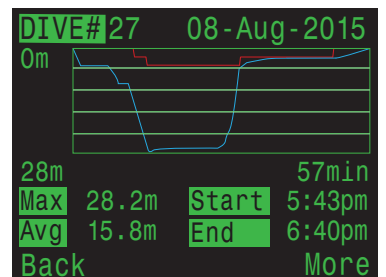

10.4.2. Edit Log

Scrolling past all screens of an individual log brings up the Edit Log page where Dive number, Date, and Time can be changed, or the dive log can be deleted.

10.4.3. Next Log

The dive log number can be edited. This is useful if you want the dive computer log numbers to match your lifetime dive count.

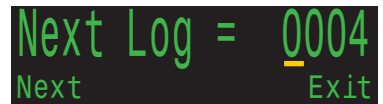

Next Log = 0004
Next Exit

This number will be applied to the next dive.

10.4.4. Restore Mode

Restore mode can be toggled on and off. When toggled on, it shows deleted logs, grayed out in the “Display Log” sub-menu. These dives can be restored to the Dive Log.



Restore Mode On
Next Edit

The Delete All Logs option is also changed to Restore All Logs when Restore mode is enabled.

10.4.5. Delete All Logs

Deletes All of the Logs.



Delete All Logs
Next Delete

Deleted Logs can be restored by toggling Restore Mode to on.

10.4.6. Start Bluetooth

Bluetooth is used for both firmware uploading and dive log downloading.



Start Bluetooth

Use this option to initialize Bluetooth on your dive computer.

11. System Setup Reference

System Setup contains configuration settings together in a convenient format for updating the configuration before a dive.

A screenshot of the 'System Setup' menu, showing the title 'System Setup' in green text on a black background.

System setup cannot be accessed during a dive.

All of the settings available in Dive Setup are available in System Setup which can be accessed during a dive. However, not all settings in System Setup can be edited in Dive Setup.

11.1. Mode Setup

The first sub-menu of System Setup is Mode Setup.

Mode

Rebreather controllers are locked in Closed Circuit mode with external sensor monitoring.

Salinity

Water type (salinity) affects how the measured pressure is converted to depth.

Settings:

- Fresh
- EN13319 (default)
- Salt

Density of freshwater and saltwater differ by about 3%. Saltwater, being denser, will display a shallower depth for the same measured pressure versus the Fresh setting.

The EN13319 value is between Fresh and Salt. It is from the European CE standard for dive computers, and is the Petrel 3's default value.

Note that this setting only affects the depth displayed on the computer and has no impact on decompression calculations which rely on absolute pressure.

PPO2 Mode

On the Petrel 3 DiveCAN Controller Models this value is always “ext.” (Externally measured PPO2).

Low and High Setpoints

Each setpoint can be set from 0.5 to 1.5.

The setpoints can also be edited, even during a dive, in the Dive Setup menu.

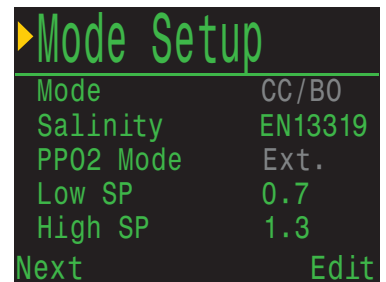
A screenshot of the 'Mode Setup' menu. The title 'Mode Setup' is in green. Below it, a list of settings is shown: 'Mode' (CC/BO), 'Salinity' (EN13319), 'PPO2 Mode' (Ext.), 'Low SP' (0.7), and 'High SP' (1.3). At the bottom, 'Next' and 'Edit' are listed in green.

11.2. Deco Setup

Deco Model

By default this will show “Buhlmann ZHL16C GF” indicating that the Bühlmann ZHL-16C with gradient factors model is being used.

An optional VPM-B decompression algorithm unlock is available at an additional cost. If applied, the deco model item allows the user to change between the available algorithms.

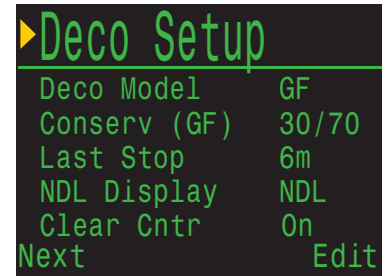

Conservatism

In technical dive modes conservatism can be adjusted in either the GF or VPM model.

For a more detailed explanation of their meaning for the GF algorithm, please refer to Erik Baker’s excellent articles: Clearing Up The Confusion About “Deep Stops” and Understanding M-values. The articles are readily available on the web.

VPM-B has conservatism settings from 0 to +5, with higher numbers being more conservative.

Last Stop

Allows you to choose where to do your last mandatory decompression stop.

The choices are 3m/10ft and 6m/20ft.

NDL Display

These options were previously covered in the Dive Setup section.

Clear Cntr

This option allows you to toggle the deco clear counter on or off.

When turned on, the counter will count up from zero in the deco area starting when decompression obligations are cleared.

11.3. AI Setup

All AI settings must be configured on the surface before a dive, since the System Setup menu is not accessible during a dive.

AI Mode

AI Mode is used to easily enable or disable AI.

AI Mode Setting	Description
Off	AI sub-system is completely powered down and consumes no power.
On	AI is enabled. When on, AI increases power consumption by about 10%.

Units

Choices are bar or psi.

11.3.1. TX Setup

The Transmitter setup (TX Setup) menu is used to set up transmitters. Currently active transmitters are shown next to TX Setup in the top level AI menu.

Up to 4 transmitters can be configured in this menu. Select a transmitter to modify its attributes.

Transmitter On/ Off

Turn off transmitters that are not currently in use to save battery power.

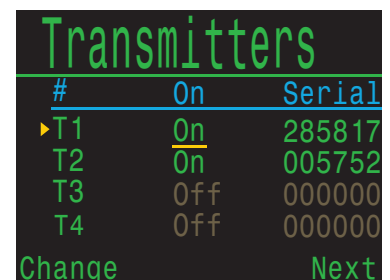
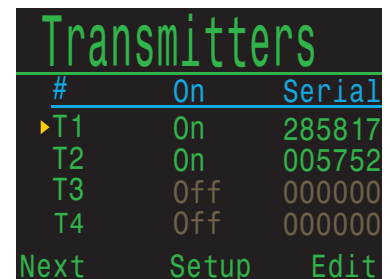

Set AI Mode to OFF when AI not in use

Leaving AI enabled when not in use will negatively impact battery life when the computer is turned on. When a paired transmitter is not communicating, the Petrel 3 goes into a higher power scan state. This increases power consumption to about 25% higher than with AI off. Once communications are established, power drops to about 10% higher than with AI off.

Note, AI is never active when the computer is off. There is no need to turn AI off when the computer is turned off.

11.3.2. Tank Setup

Navigate over to and select a transmitter's serial number in the transmitter setup menu to enter the tank set up menu for that transmitter.

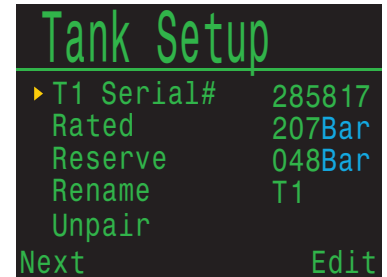

Serial Number Setup

Every transmitter has a unique 6-digit serial number. This number is etched onto the side of the transmitter.

Enter the serial number to pair the transmitter to T1. This number only needs to be entered once. Like all settings, it is stored in permanent memory.



Rated Pressure

Enter the rated pressure of the tank on which the transmitter is installed.

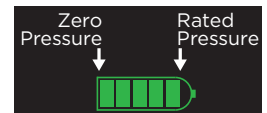

The valid range is 69 to 300 bar (1000 to 4350 psi).

The only use of this setting is to scale the full-scale range of the gas pressure bar graph that appears over the numerical tank pressure number.

Reserve Pressure

Enter the reserve pressure.

The valid range is 28 to 137 bar (400 to 2000 psi).
The default reserve pressure value is 50 bar (725 psi).

The reserve pressure setting is used for low pressure warnings

A “**Reserve Pressure**” warning will be generated when the tank pressure falls below this setting.

A “**Critical Pressure**” warning will be generated when the tank pressure falls below the larger of 21 bar (300 psi) or half the reserve pressure.

For example, if reserve pressure is set to 48 bar, the critical warning will occur at 24 bar (48/2). If the reserve pressure is set to 27 bar, the critical warning will occur at 21 bar.

Rename

Allows the changing of the transmitters title as it appears on menus and screens throughout the dive computer. Two characters can be customized per tank. The options are:

First Character: T,S,B,O, or D.

Second Character: 1,2,3, or 4.

Unpair

The unpair option is simply a shortcut to reset the serial number to 000000.

When not using T1 or T2, for lowest power consumption, disable receiving completely by setting the AI Mode setting to Off.

GTR Mode

Gas time remaining and Sac are not available on rebreather controllers.

11.4. BO Gases

This menu allows the user to edit the open circuit bailout gas list. The options contained here are the same as those in the “Define Gases” subsection of the “Dive Setup” section. This menu page conveniently displays all five gases simultaneously.

Each gas can be turned on or off and set to any concentration of O2 and helium. The remaining percentage is assumed to be nitrogen.

The active gas is shown with a leading ‘A’. All gases that are turned off are drawn in magenta (purple).

BO Gases			
1	OC	On	99/00
2	OC	On	50/00
A3	OC	On	14/55
4	OC	Off	00/00
5	OC	Off	00/00
Next		Edit	

11.5. CC Gases

This menu allows the user to edit the closed circuit diluent gas list. The options contained here are the same as those in the OC Gas list setup menu.

CC Gases			
A1	CC	On	10/50
2	CC	Off	00/00
3	CC	Off	00/00
4	CC	Off	00/00
5	CC	Off	00/00
Next		Edit	

11.6. O2 Setup

Cal. FO2

This setting allows you to set the fraction of oxygen (FO2) of the calibration gas.

The calibration gas FO2 can be set from 0.70 to 1.00. The default value of 0.98 is for pure oxygen, but assumes about 2% water vapor due to the diver’s breathing on the loop during the flushing process.

O2 Setup	
Cal. FO2	0.98
Sensor Disp	Giant
Next	
Edit	

NOTE: This setting value is the fraction of oxygen, not the partial pressure of oxygen. When the calibration is performed, the Petrel measures the ambient barometric pressure to determine the PPO2. If you are at sea-level, and do not want small variations in barometric pressure changing the calibrated PPO2 result, there is an option to set the Altitude to a SeaLvl.

Sensor Disp

Sets the sensor display mode on the center row of the main screen. The available settings are:

- Large: the PPO2 text is the normal large font.
- Giant: the PPO2 text is larger.

11.7. Auto Setpoint Switch

This page sets up automatic setpoint switching. The dive computer can be set up to auto switch the setpoint up only, down only, both, or neither.

First, you set whether the “Up” switch occurs automatically or manually. If “Up” is set to “Auto”, then you can set the depth at which the auto switch occurs.

```
▶Auto SP Switch
Up:    0.7>1.3  Auto
Up Depth  021m

Down:   1.3>0.7  Auto
Down Depth 012m
Next      Edit
```

The menu options are the same for the down setpoint switch.

When a switch is set to “Auto”, you can always manually override the setting at any time during the dive.

The automatic switches only occur when crossing the specified depth. Say for example, the switch up depth is set to 15m. You start the dive on the low setpoint, then as you descend past 15m, the setpoint automatically switches up to high. If at 24m you then manually switch back to the low setpoint, the setpoint will remain low. If you ascend shallower than 15m then re-descend deeper than 15m again, the automatic setpoint switch will occur again.

The Petrel 3 enforces a 6m (20ft) gap between switch up and switch down depths to prevent rapid automatic switching between setpoints for small depth changes. The values 0.7 and 1.3 are shown as examples only. Other values for the low and high setpoint can be adjusted in the Dive Setup or Mode Setup menu.

Auto setpoint switch example:

The settings displayed to the right would cause the computer to behave as follows.

The low to high auto setpoint switch is enabled at a depth of 21 meters.

```
Up:    0.7>1.3  Auto
Up Depth  021m
```

The dive starts at the 0.7 setpoint. As you descend past 21m, the setpoint switches “up” to 1.3.

You finish your bottom time, then begin ascending.

The high to low auto setpoint switch is enabled at a depth of 12 meters.

```
Down:   1.3>0.7  Auto
Down Depth 012m
```

When you ascend above 12, the setpoint switches “down” to 0.7.

11.8. Alerts Setup

This page is used to set up custom dive alerts for Maximum Depth, Time, and Low NDL. Notifications will be triggered when these values are exceeded.

You can also toggle the vibration function from this page.

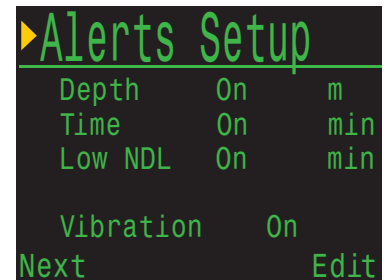

11.9. Display Setup

Depth and Temperature

Depth: Feet or Meters

Temperature: °F or °C

Brightness

See brightness options in section 10.8.3.

Altitude

The altitude setting on the Petrel 3 is set to Auto by default. In this mode the computer will automatically compensate for pressure changes when diving at altitude. If all your diving is at sea level, then setting this to 'SeaLvl' will assume that surface pressure is always 1013 mbar (1 atmosphere).

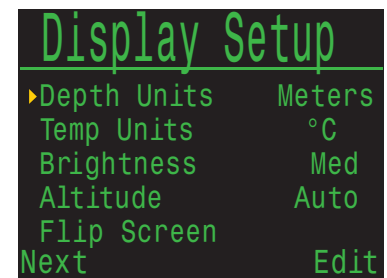

Diving At Altitude

When diving at altitude you must set this option to 'Auto' or incorrect decompression calculations could result.

Further, when diving at altitude, you **must** turn the computer on at the surface. If the auto-on safety feature is allowed to turn the computer on after a dive has started then the computer assumes the surface pressure is 1013 mbar. If at altitude this could result in incorrect decompression calculations.

Flip Screen

Displays the contents of the screen upside down. This is useful if you wish to wear your controller on the right arm.



Determination of Surface Pressure

Accurate depth measurements and decompression calculations require knowing the ambient atmospheric pressure at the surface. Regardless of the turn on method, the surface pressure is determined the same way. While in the off state the surface pressure is measured and saved every 15 seconds. A 10 minute history of these pressure samples is kept. Immediately after turn on this history is examined and the minimum pressure is used as the surface pressure. The surface pressure is then remembered, and not updated again until the next turn on.

11.10. Compass

Compass View

The Compass View setting can be set to the following options:

Off: The compass is disabled.

60°, 90°, or 120°: Sets the range of the compass dial that is visible on the main screen. The actual amount of arc that there is room for on the screen is 60°, so this may feel the most natural. The 90° or 120° settings allow a wider range to be seen at once. The default is 90°.

True North (declination)

Enter the declination of current position to correct compass to true north.

This setting can be set from -99° to +99°.

If matching an uncompensated compass, or navigation is based on relative directions, then this setting can be left at 0°.

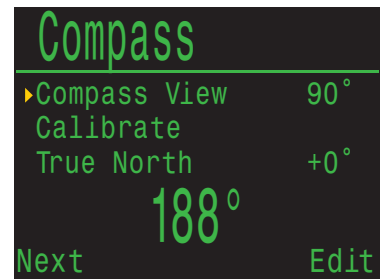

Calibrate

Calibration of the compass may be needed if the accuracy drifts over time or if a permanent magnet or ferromagnetic metal (e.g. iron or nickel) object is mounted very close to the Petrel 3. To be calibrated out, such an object must be mounted with the Petrel 3 such that it moves along with the Petrel 3.

Compare the Petrel 3 with a known good compass or fixed references to determine if calibration is needed. If comparing against fixed references, remember to consider the local deviation between Magnetic North and True North (declination). Calibration is typically not needed when traveling to different locations. The adjustment needed then is the True North (declination).

When calibrating, rotate the Petrel 3 smoothly through as many 3D twists and turns as possible in 15 seconds.



Calibrate the Compass Each Battery Change

Each battery has its own magnetic signature, mostly due to its steel case. Therefore, recalibrating the compass when changing batteries is recommended.



Compass Calibration Tips

The following tips will help ensure a good calibration:

- Stay away from metal (especially steel or iron) objects. For example, wrist watches, metal desks, boat decks, desktop computers, etc. These can all interfere with the Earth's magnetic field.
- Rotate to as many 3D positions as possible. Upside down, sideways, on edge, etc.
- Compare with an analog compass to check calibration.

11.11. System Setup

Date

Allows the user to set the current date.

Clock

Allows the user to set the current time. The format can be set to AM, PM or 24 hour time.

Unlock

Only to be used at the direction of Shearwater technical support.

Log Rate

Sets how often dive samples are added to the computer's log. More samples will give a higher resolution dive log at the expense of log memory. Default is 10 seconds. Maximum resolution is 2 seconds.

Reset to Defaults

The final 'System Setup' option is 'Reset to Defaults'. This will reset all user changed options to factory settings and/or clear the tissues on the dive computer. 'Reset to Defaults' cannot be reversed.

Note: This will not delete dive logs, or reset dive log numbers.

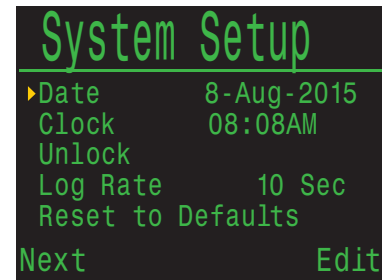

11.12. Advanced Config

Advanced configuration contains items that will be used infrequently and can be ignored by most users. They provide more detailed configurations.

The first screen allows you to enter the advanced configuration area, or to set the advanced configurations settings to their default.

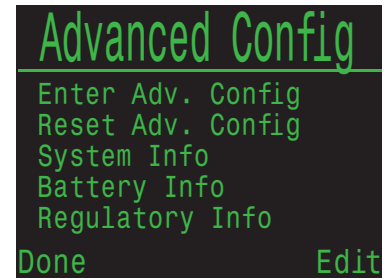

Reset Adv. Config

This will reset all advanced config values to their default settings.

Note: This will not affect other computer settings, delete dive logs, or reset dive log numbers.

System Info

The System Info section lists the computer's serial number as well as other technical information you may be asked to provide to tech support for troubleshooting purposes.

Battery Info

This section gives additional information on the type of battery being used and battery performance.

Regulatory Info

This section is where a user can find the specific model number of their computer as well as additional regulatory information.

11.12.1. Advanced Config 1

Main Colour

Main colours can be changed for user preference. Default is green. The other option is red.

Consider the impact on colour coded warnings if changing the colour to red.

Title Colour

The title colors can be changed for added contrast or visual appeal. Default is Cyan, with gray, white, green, red, pink, and blue also available.

End Dive Delay

Sets the time in seconds to wait after surfacing before ending the current dive.

This value can be set from 20 seconds to 600 seconds (10 minutes). Default is 60s.

This value can be set to a longer time if you want brief surface intervals connected together into one dive. Alternatively, a shorter time can be used to exit dive mode more quickly upon surfacing.

Battery Icon

The behavior of the battery icon can be changed here. Options are:

- **Surf+Warn:** The battery icon always displays when on the surface. During dive it displays only if there is a low battery warning.
- **Always:** The battery icon always displays.
- **Warn Only:** The battery icon only appears when there is a low battery warning.

Gas Select

The feature is described in the Select Gas Menu Style Options section.

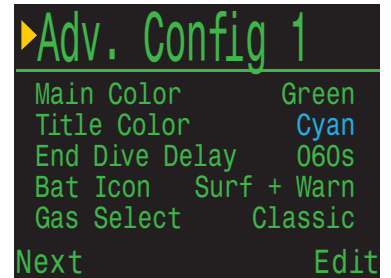

11.12.2. Advanced Config 2

PPO2 Limits

This section allows changing of PPO2 limits.



WARNING

Do not change these values unless you fully understand the effect.

All values are in absolute atmospheres [ATA] of pressure.
(1 ATA = 1.013 bar)

OC Low PPO2

PPO2 of all gases display in flashing red when less than this value. (Default 0.18)

OC MOD PPO2

This is the maximum allowable PPO2 during the bottom phase of the dive - **Maximum Operating Depth**. (Default 1.4)

OC Deco PPO2

All decompression predictions (Deco schedule and TTS) assume that the gas used for decompression at a given depth will be the gas with the highest PPO2 that is less than or equal to this value. (Default 1.61)

Suggested gas switches (when the current gas is displayed in yellow) are determined by this value. If you change this value, please be sure you understand its effect.

For example, if lowered to 1.50, then a switch to oxygen (99/00) will not be assumed at 6m/20ft.

CC Min PPO2

PPO2 displays in flashing red when less than this value. (Default 0.40)

CC Max PPO2

PPO2 displays in flashing red when greater than this value. (Default 1.60)

Note: In both CC and BO modes, “Low PPO2” or “High PPO2” alerts are displayed when the limits are violated for more than 30 seconds.

▶ Adv. Config 2		
OC Min.	PP02	0.18
OC Mod.	PP02	1.40
OC Deco	PP02	1.61
CC Min.	PP02	0.40
CC Max.	PP02	1.60
Next		Edit

11.12.3. Advanced Config 3

Button Sensitivity

This menu allows some fine tuning of button sensitivity. This can be useful to adjust downward if you often experience accidental button presses.

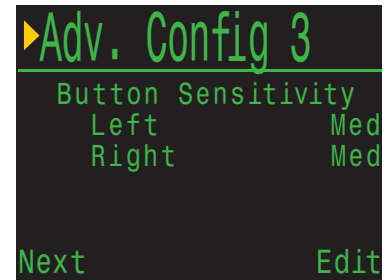

11.12.4. Advanced Config 4

Stack Timer

A stack timer is available for tracking the amount of time spent diving with a CO2 absorbent canister.

It can be toggled on and off in the Advanced Config. 4 menu. The total time can be set anywhere between and 1h and 9h 59m. The stack timer can be set to count down either when diving, or when the computer is ON. A warning will alert the diver when the stack timer has 1h remaining and an alarm will be displayed when the stack timer has 30 minutes remaining.



The current stack timer count used and remaining will be available as an info screen when the stack timer is enabled. The stack timer can also be reset from the main level menu. The stack timer cannot be reset during a dive.

12. Firmware Update and Log Download

It is important to keep the firmware on your rebreather controller up to date. In addition to new features and improvements, firmware updates address important bug fixes.

There are two ways to update the firmware on your Petrel 3:

- 1) With Shearwater Cloud Desktop
- 2) With Shearwater Cloud Mobile



Upgrading the firmware resets decompression tissue loading. Plan repetitive dives accordingly.



During the update process, the screen may flicker or go blank for a few seconds.

12.1. Shearwater Cloud Desktop



Ensure you have the most recent version of Shearwater Cloud Desktop.
[Shearwater.com/cloud](https://www.shearwater.com/cloud)

Connect to Shearwater Cloud Desktop

On your Petrel 3, start Bluetooth by selecting the Bluetooth menu item from the main menu.



In Shearwater Cloud Desktop:

1. Click the connect icon to open the connect tab.
2. Scan for Dive Computer
3. Once you've connected the computer once, use the Petrel 3 tab to connect faster next time

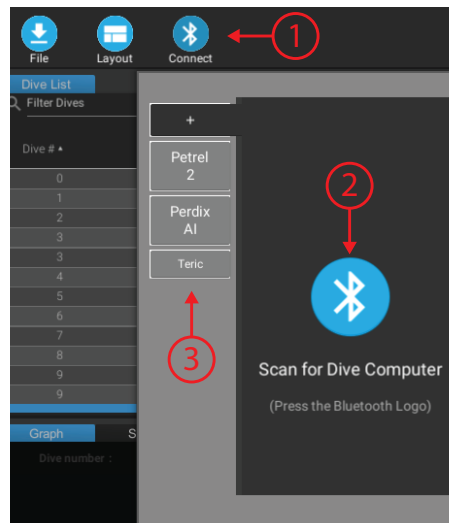

Shearwater Cloud Desktop Connect Tab

Once the Petrel 3 is connected, the connect tab will show a picture of the dive computer.

Download Dives

Select “Download Dives” from the connect tab.

A list of dives will be generated. You can un-select any dive logs you don’t want to download, then press OK.

Shearwater Cloud Desktop will transfer the dives to your computer.

From the connect tab, you can give the Petrel 3 a name. If you have multiple Shearwater dive computers, you will be able to easily tell which dive was downloaded from which dive computer.

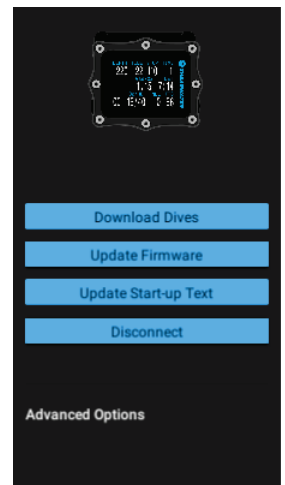

Shearwater Cloud Desktop Connect Tab

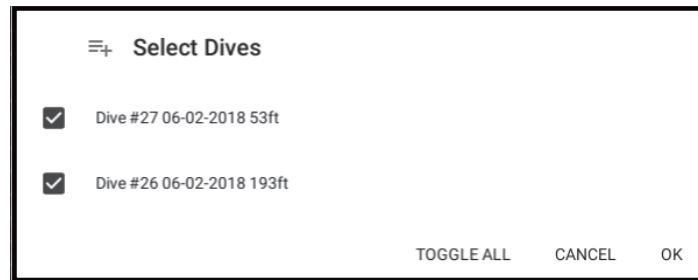

Select the dives you wish to download and press OK

Update Firmware

Select “Update Firmware” from the connect tab.

Shearwater Cloud Desktop will automatically select the latest available firmware.

When prompted, select your language and confirm the update.

The Petrel 3 screen will give percentile updates of receiving the firmware, and then the Personal Computer will read “Firmware successfully sent to the computer” on completion.



Firmware updates can take up to 15 minutes.

Update Start-up Text

Start-Up text appears at the top of the start up splash screen when the Petrel 3 is turned on. It's a great place to put your name and phone number so your computer can be more easily returned if mis-placed.

Update Start-up Image

Here you can also change the startup image that appears when the Petrel 3 turns on to help better differentiate your dive computer.

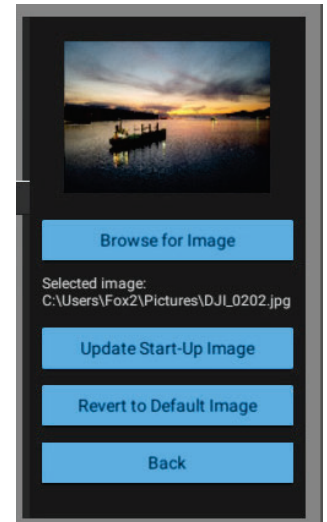

Update Start-up Image

12.2. Shearwater Cloud Mobile



Ensure you have the most recent version of Shearwater Cloud Mobile.

Download it from [Google Play](#) or the [Apple App Store](#).

Connect to Shearwater Cloud Mobile

On your Petrel 3, start Bluetooth by selecting the Bluetooth menu item from the main menu.



On Shearwater cloud mobile:

1. Press the connect icon at the bottom of the screen
2. Select your Petrel 3 from the list of Bluetooth devices

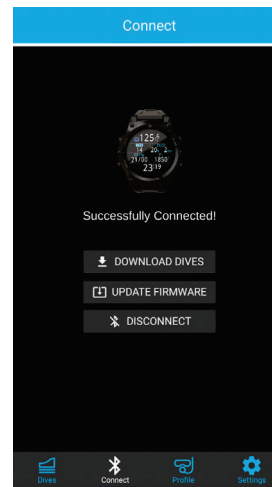
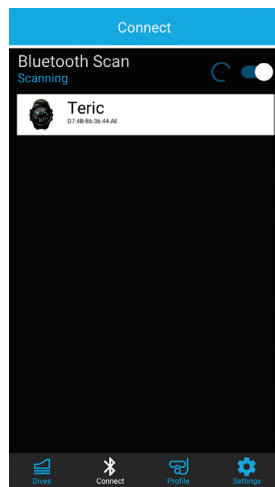

Download Dives

Select “Download Dives”

A list of dives will be generated and you can un-select any dive logs you don't want to download, then press OK.

Shearwater Cloud will transfer the dives to your smart phone.

Update Firmware

Once the Petrel 3 is connected to Shearwater cloud mobile, select “Update Firmware” from the connect tab.

Shearwater Cloud mobile will automatically select the latest available firmware.

When prompted, select your language and confirm the update.

The Petrel 3 screen will give percentile updates of receiving the firmware, and then the mobile app will read “Firmware successfully sent to the computer” on completion.

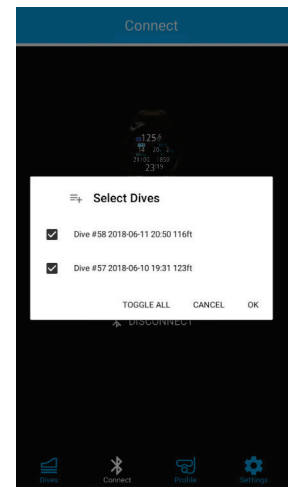

 Firmware updates can take up to 15 minutes.

13. Changing the Battery

A large coin or washer is required to change the battery

Remove the battery cap

Insert the coin or washer into the battery cap slot. Unscrew by turning counter clockwise until the battery cap is free. Be sure to store the battery cap in a clean dry space.

Exchange the battery

Remove the existing battery by tilting the Petrel 3 and letting the old battery slide out. Insert a new battery positive contact first. A small diagram on the bottom of the Petrel 3 shows the proper orientation.

Reinstalling the battery cap

It is **very important that the battery cap O-rings are clear of dust or debris.**

Carefully inspect the O-rings for any debris or damage and gently clean. It is recommended that the battery cap's O-ring is lubricated on a regular basis with an O-ring lubricant compatible with Buna-N (Nitrile) O-rings. Lubricating helps ensure that the O-ring seats properly and does not twist or bunch.

Insert the battery cap into the Petrel 3 and compress the battery contact springs. While the springs are compressed rotate the battery cap clockwise to engage the threads. Be sure not to cross thread the battery cap's threads. Tighten the battery cap until snug and the Petrel 3 powers on. Do not over tighten the battery cap.

NOTE: Battery cap O-rings are Type 112 Buna-N 70 durometer.

13.1. Battery Type Selection

After changing the battery, select the battery type used.

The Petrel 3 attempts to guess what type of battery is being used. If the battery type is incorrect, it should be manually edited.

The Petrel 3 can accept most AA sized (14500 size) batteries that output a voltage between 0.9 V and 4.3V. However, some batteries are better than others.

- Not all batteries support vibration.
- Battery types that support the fuel gauge feature will give more warning before the computer dies.
- Some battery types perform better in cold water.

Shearwater recommends using Energizer Ultimate Lithium batteries for best performance.

Supported battery types:

Battery Type	Approx. Battery Life	Vibration Support	Fuel Gauge	Cold water Performance
1.5V Lithium Recommended	60 hours	Yes	Yes	Very Good
1.5V Alkaline	45 hours	No	Yes	Ok
1.2V NiMh Rechargeable	30 hours	No	No	Poor
3.6V Saft LS14500	130 hours	No	No	Poor
3.7V Li-Ion Rechargeable	35 hours	Yes	Yes	Good

Battery life is based on medium brightness.



Alkaline batteries are especially prone to leaking. This is a leading cause of dive computer failure.

Alkaline batteries are not recommended.

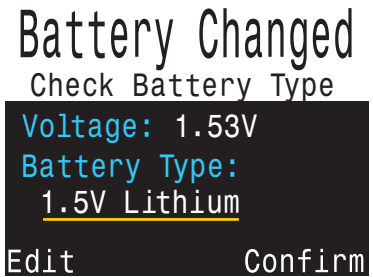

13.2. Behavior on Battery Change

Settings

All settings are retained permanently. No loss of settings occurs when changing the battery.

Clock

The clock (time and date) is saved to permanent memory every 16 seconds when the dive computer is on, and every 5 minutes when off. When the battery is removed, the clock stops running. Once the battery is replaced, the clock is restored to the last saved value (so it is best to remove the battery while the dive computer is on for lowest error).

Quick battery changes will not require any adjustment, but the time should be corrected if the battery is removed for more than a few minutes.

Expected clock drift is about 4 minutes per month. If there is higher drift, it is likely due to clock stoppage during battery changes, and is easily corrected at the time of a battery change.

The clock is also updated every time the dive computer is connected to Shearwater Cloud Desktop or Shearwater Cloud Mobile.

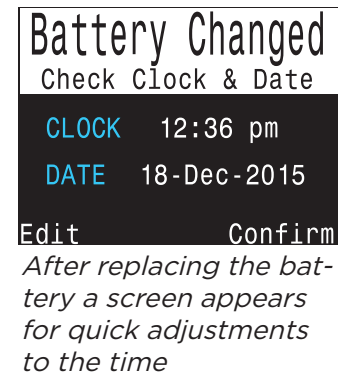

13.2.1. Decompression Tissue Loading

The battery may be safely changed between repetitive dives.

Like the clock, the decompression tissue loading is saved every 16 seconds to permanent memory when on, and every 5 minutes when off.

When the battery is removed the tissues remain stored in the permanent memory and are restored once the battery is replaced, allowing for battery changes between repetitive dives. However, the dive computer does not know for how long the battery was removed, so no surface interval adjustment is applied for the time that the battery is removed.

For quick battery changes, the un-powered time interval is not significant. However, if the battery is removed shortly after a dive and then remains out for a long period, residual tissue loading will remain when the battery is replaced.

If at the time of battery replacement any tissue is below saturated with air at the current pressure, then that tissue is brought up to being saturated with air. This might happen after a decompression dive that used 100% O₂, where the faster tissues are often completely depleted of inert gas loading. Bringing such tissues back up to saturated with air after a battery change is the most conservative approach.

When deco tissues are reset:

- Inert gas tissue loadings are set to saturated with air at current atmospheric pressure
- CNS Oxygen Toxicity set to 0%
- Surface Interval time set to 0
- All VPM-B values set to default levels

14. Storage and Maintenance

The Petrel 3 dive computer should be stored dry and clean.

Do not allow salt deposits to build up on the dive computer. Rinse the computer with fresh water to remove salt and other contaminants.

Do not wash under high pressure jets of water as it may cause damage to the depth sensor.

Do not use detergents or other cleaning chemicals as they may damage the dive computer. Allow to dry naturally before storing.

Store the dive computer **out of direct sunlight** in a cool, dry and dust free environment. Avoid exposure to direct ultra-violet radiation and radiant heat.

Do not store batteries in the Petrel 3 for long periods (several months). Batteries can leak, so don't risk your expensive computer on a simple task like removing batteries. Dead batteries are at a higher risk of leaking. Leaking batteries is a leading cause of dive computer failure and is not covered under warranty.

15. Servicing

There are no user serviceable parts inside the Petrel 3. Do not tighten or remove any faceplate screws.

Clean with water ONLY. Any solvents may damage the Petrel 3 dive computer.

Service of the Shearwater Petrel 3 may only be done at Shearwater Research, or by any of our authorized service centers.

Contact Info@shearwater.com for service requests.

Shearwater recommends service of all dive computers every 2 years by an authorized service center.

Evidence of tampering will void your warranty.

16. Glossary

CC - Closed circuit. Scuba diving using a rebreather where exhaled gas is recirculated with carbon dioxide removed.

GTR - Gas Time Remaining. The time, in minutes, that can be spent at the current depth and SAC rate until a direct ascent to the surface would result in surfacing with the reserve tank pressure.

NDL - No Decompression Limit. The time, in minutes, that can be spent at the current depth until mandatory decompression stops will be required.

O₂ - Oxygen gas.

OC - Open circuit. Scuba diving where gas is exhaled into the water (i.e. most diving).

PO₂ - Partial Pressure of Oxygen, sometimes PPO₂.

RMV - Respiratory Minute Volume. Gas usage rate measured as the volume of gas consumed, adjusted as if at a pressure of one atmosphere. Units of Cuft/minute or L/minute.

SAC - Surface Air Consumption. Gas usage rate measured as the rate of tank pressure change, adjusted as if at a pressure of one atmosphere (i.e. surface pressure). Units of psi/minute or bar/minute.

17. Specifications

Specification	Petrel 3 Model Dive Can Controller
Operating Modes	Closed Circuit (CC) Open Circuit Bailout (BO)
Display	Full color 2.6" AMOLED
Pressure (depth) sensor	Piezo-resistive
Accuracy	+/-20 mbar (at surface) +/-100 mbar (at 14bar)
Calibrated Depth Sensor Range (Maximum Rated Depth)	0 bar to 14 bar (130 msw, 426 fsw)
Crush Depth Limit	30 bar (~290msw) Note: this exceeds the calibrated depth sensor range.
Surface Pressure Range	500 mbar to 1040 mbar
Depth of dive start	1.6 m of sea water
Depth of dive end	0.9 m of sea water
Operating Temperature Range	+4°C to +32°C
Short-Term (hours) Temperature Range	-10°C to +50°C
Long-Term Storage Temperature Range	+5°C to +20°C
Battery	User Replaceable AA Size, 0.9V to 4.3V
Battery Operating Life (Display Medium Brightness)	45 Hours (AA 1.5V Alkaline) 60 Hours (1.5V Lithium) 130 Hours (SAFT LS14500)
Communications	Bluetooth Low Energy (4.0)
Compass Resolution	1°
Compass Accuracy	±5°
Compass Tilt Compensation	Yes, over ±45° pitch and roll
Dive Log Capacity	Approximately 1000 hours
Battery cap o-ring	Dual o-rings. Size: AS568-112 Material: Nitrile Durometer: 70A
Wrist Attachment	2 x 3/4" Elastic Straps with Buckles
Weight	DiveCAN Cable Gland (DCG) Model - 345g
Size (W X L X H)	83mm X 75.5mm X 39mm

18. List Of Petrel 3 Models

The following is a list of Petrel 3 models to which this manual is applicable. The model / part number and Petrel 3 variant can be found on the Regulatory Information screen of the System Setup Menu (System Setup > Advanced Config > Regulatory Info).

All models to which this manual applies are DiveCAN cable gland variant, controller models (DCG /DCC).

Model/Part Number
11304
11305
11306
11307
11308
11310
11312
11313
11316

The Petrel 3 comes in 4 variants:

1. Stand Alone (SA) - The stand alone variant has no connection to a rebreather.
2. Fischer Connector (FC) - The Fischer connector is a bulkhead connector that is commonly used on manual rebreathers. This Petrel 3 variant interprets signals from galvanic oxygen cells over the Fischer connection.
3. Analog Cable Gland (ACG). - The analog cable gland is a newer alternative to the Fischer connector variant. This variant has a permanently attached cable that can be connected to a compatible rebreather to interpret signals from galvanic oxygen cells.
4. DiveCAN Cable Gland (DCG). - The DiveCAN cable gland variant is built for use exclusively with DiveCAN supported rebreather systems. This manual is only applicable to DiveCAN cable gland Petrel 3 controllers (DCC), all of which listed in the table above. For DiveCAN monitors (DCM) operating instructions, please see the Petrel 3 Technical Modes operating instructions manual.

19. Regulatory Information

A) USA-Federal Communications Commission (FCC)

THIS DEVICE COMPLIES WITH PART 15 OF THE FCC RULES. OPERATION IS SUBJECT TO THE FOLLOWING TWO CONDITIONS:

(1) THIS DEVICE MAY NOT CAUSE HARMFUL INTERFERENCE, AND

(2) THIS DEVICE MUST ACCEPT ANY INTERFERENCE RECEIVED, INCLUDING INTERFERENCE THAT MAY CAUSE UNDESIRE OPERATION.

Changes to or modification of this equipment are not authorized, doing so may void the user's authority to operate this equipment.

Note: This equipment has been tested and found to comply with the limits for a Class B digital device, pursuant to part 15 of the FCC Rules. These limits are designed to provide reasonable protection against harmful interference in a residential installation. This equipment generates, uses and can radiate radio frequency energy and, if not installed and used in accordance with the instructions, may cause harmful interference to radio communications. However, there is no guarantee that interference will not occur in a particular installation. If this equipment does cause harmful interference to radio or television reception, which can be determined by turning the equipment off and on, the user is encouraged to try to correct the interference by one or more of the following measures:

—Reorient or relocate the receiving antenna.

—Increase the separation between the equipment and receiver.

—Connect the equipment into an outlet on a circuit different from that to which the receiver is connected.

—Consult the dealer or an experienced radio/TV technician for help

Caution: Exposure to Radio Frequency Radiation.

This device must not be co-located or operating in conjunction with any other antenna or transmitter.

Petrel 3 Dive Computer Contains TX FCC ID: **2AA9B04**

B) Canada - Industry Canada (IC)

This device complies with RSS 210 of Industry Canada.

Operation is subject to the following two conditions:

(1) this device may not cause interference, and

(2) this device must accept any interference, including interference that may cause undesired operation of this device.

L'utilisation de ce dispositif est autorisée seulement aux conditions suivantes :

(1) il ne doit pas produire d'interférence, et

(2) l'utilisateur du dispositif doit être prêt à accepter toute interférence radioélectrique reçue, même si celle-ci est susceptible de compromettre le fonctionnement du dispositif.

Caution: Exposure to Radio Frequency Radiation.

The installer of this radio equipment must ensure that the antenna is located or pointed such that it does not emit RF field in excess of Health Canada limits for the general population; consult Safety Code 6, obtainable from Health Canada's [website](#).

Petrel 3 Dive Computer Contains TX IC: **I2208A-04**

C) EU and UK Conformance Statements

- EU Type examination conducted by: SGS Fimko Oy Ltd, Takomotie 8, FI-00380 Helsinki, Finland. Notified Body No. 0598.
- UK Type examination conducted by: SGS United Kingdom Ltd, Rossmore Business Park, Ellesmere Port, South Wirral, Cheshire, CH65 3EN, United Kingdom. Approved Body No. 0120.
- This device is in conforms with REGULATION (EU) 2016/425 on personal protective equipment.
- High pressure gas sensing components are in conformity with EN 250:2014 – respiratory equipment -open circuit self-contained compressed air diving apparatus – requirements, testing and marking – clause 6.11.1 Pressure Indicator. Pressure indication is designed to protect a trained diver from the risk of drowning.
- EN 250:2014 is the standard describing certain minimum performance requirements for SCUBA regulators to be used with air only sold in EU. EN 250:2014 testing is performed to a maximum depth of 50 M (165 FSW). A component of self-contained breathing apparatus as defined by EN 250:2014 is: Pressure Indicator, for use with air only. Products marked EN250 are intended for air use only. Products marked EN 13949 are intended for use with gases containing more than 22% oxygen and must not be used for air.
- Depth and time measurements conform with EN 13359:2000 - Diving Accessories - depth gauges and combined depth and time monitoring devices
- Electronic instruments are in compliance with:
 - ETSI EN 301 489-1, v2.2.3: 2019 Electromagnetic compatibility (EMC) standard for radio equipment and services; Part 1: Common technical requirements.
 - ETSI 301 489-17 V3.2.4:2020 ElectroMagnetic Compatibility (EMC) standard for radio equipment and services; Part 17: Specific conditions for Broadband Data Transmission Systems.
 - EN 55035:2017/A11:2020 Electromagnetic compatibility of multimedia equipment. Immunity requirements.
 - CISRP32/EN 55032, 2015. A11:2020 Electromagnetic compatibility of multimedia equipment. Emission requirements.
 - DIRECTIVE 2011/65/EU Restriction of the use of certain hazardous substances in electrical and electronic equipment (ROHS)
- Declarations of Conformity are available at: <https://www.shearwater.com/iso-9001-2015-certified/>

EU Authorised Representative:
24hour-AR,
Van Nelleweg 1
3044 BC Rotterdam
The Netherlands

UK Authorised Representative:
24hour-AR
15 Beaufort Court
Admirals Way
Canary Wharf
London
E14 9XL

WARNING: Transmitters marked EN 250 are certified for use with air only. Transmitters marked EN 13949 are certified for use with Nitrox only.



20. Contact

www.shearwater.com/contact

Headquarters
100-10200 Shellbridge Way,
Richmond, BC
V6X 2W7
Tel: +1.604.669.9958
info@shearwater.com

End of Manual